

# V-TYPE FLOW METER OPERATING INSTRUCTIONS

## 1. PRINCIPLE OF OPERATION

A tapered glass flow tube, and a metallic float inside it, constitutes the heart of variable area type flow meters.

Flow meters are installed vertically in lines carrying gases or liquids to be monitored.

Fluids enter through the smaller opening at the bottom, and exit through the upper end. Upward pressure causes the float to rise. Flow takes place through the circular area between the float and the inside surface of the flow tube. As the float rises, the flow area increases, due to the tapered bore of the flow tube.

Dynamic equilibrium results when the buoyant force, due to the float and the upward force, due to fluid pressure, balance the weight of the float.

The vertical position of the float at equilibrium corresponds exclusively to one particular flow rate. This flow rate is obtained by determining the height of the float with the aid of the scale on the flow tube.

## 2. MATERIALS OF CONSTRUCTION

**Tube Shields:** Polycarbonate  
**Flow tubes:** Heavy walled precision formed borosilicate glass  
**Floats:** Type 316 stainless steel  
**Wetted Parts:** Brass or type 316 stainless steel  
**Seals:** Viton®  
**Scales:** Direct reading

V-meters are designed with unique rotatable scales of dual air-water direct reading graduations showing SCFM and SLPM for AIR, as well as GPM and LPM for WATER. An accessible knurl, located on the lower back portion of the meter enables rotation of the scale.

## 3. METER SPECIFICATIONS

Standard Accuracy:  $\pm 5\%$  FS  
Repeatability:  $\pm 0.25\%$   
Max. Operating Pressure: 150 psig/10bars  
Max. Operating Temperature: 250°F/121°C  
Fittings: 3/8"-18" NPT Female

All meters are factory tested for leakage prior to shipping. For hazardous fluids the flow meter must be re-tested at the time of installation in the

system, prior to usage. It is also important that a leak integrity test is performed periodically to maintain safe operating conditions. Flow meters must be protected from breakage due to external conditions such as objects bumping into or hitting the instrument, extreme vibrations, or attack by corrosive materials. It is the responsibility of the customer to acquaint the operator(s) of this flow meter with all appropriate safety information.

## 4. INSTALLATION AND OPERATION

### 4.1 Receipt of Equipment

Inspect instrument for possible visible damage resulting from shipping. Notify UPS or other carrier as well as the distributor where the flow meter was purchased of any claims.

### 4.2 Installation

Flow meters always must be installed in a vertical position, any significant deviation from vertical will effect the readings.

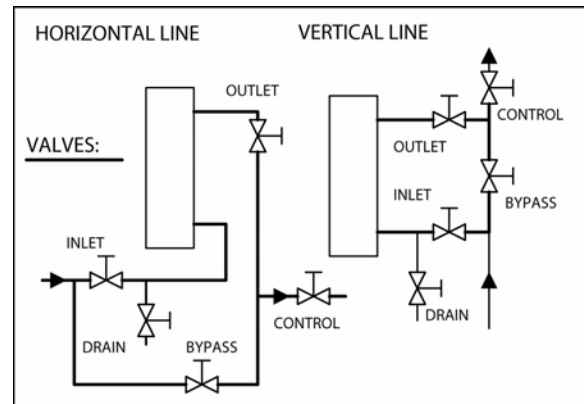

**⚠** Valves should be closed before installation and opened gradually after all connections are carefully inspected. A leak test is highly recommended especially when hazardous fluids are involved.

**CAUTION:** Excessive tightening of valves may damage the orifice.

It is important that **all lines to be connected to the flow meter are purged** of any dust or other residual contamination prior to installing the meter. In some applications a filter should be installed at the inlet of the flow meter.

# V-TYPE FLOW METER OPERATING INSTRUCTIONS

## 4.3 Operation

V style flow meters are designed to be operated at pressures not exceeding 150psig (10 bars), or temperatures not exceeding 250° F (121°C).

Close valve (if applicable) before initial use, then pressurize the system.

Slowly open the valve until the float is at the desired flow rate. Each scale indicates where on the float the flow rate should be read.

## 5. FLOW TUBE INSTALLATION/REMOVAL

**⚠ Do not remove the flow tube from the flow meter.**

Please contact Customer Service.

## 6. MAINTENANCE

Under normal operating conditions no special maintenance is required. Dirt or contamination may create problems within the flow tube by causing a restriction in the flow passage. Such conditions can be diagnosed by examining the flow tube.

The most obvious indication of obstructions is the float being stuck in the flow tube. If the existence of contamination is determined the condition may be rectified in a number of ways. The easiest being (if possible), to disconnect the inlet and the outlet of the flow meter and purge the instrument by using a clean and dry stream of gas.

The action of the float within the bore of the flow tube very often causes particles or impediments to be dislodged through the outlet of the flow meter.

## 7. DIMENSIONAL DIAGRAMS

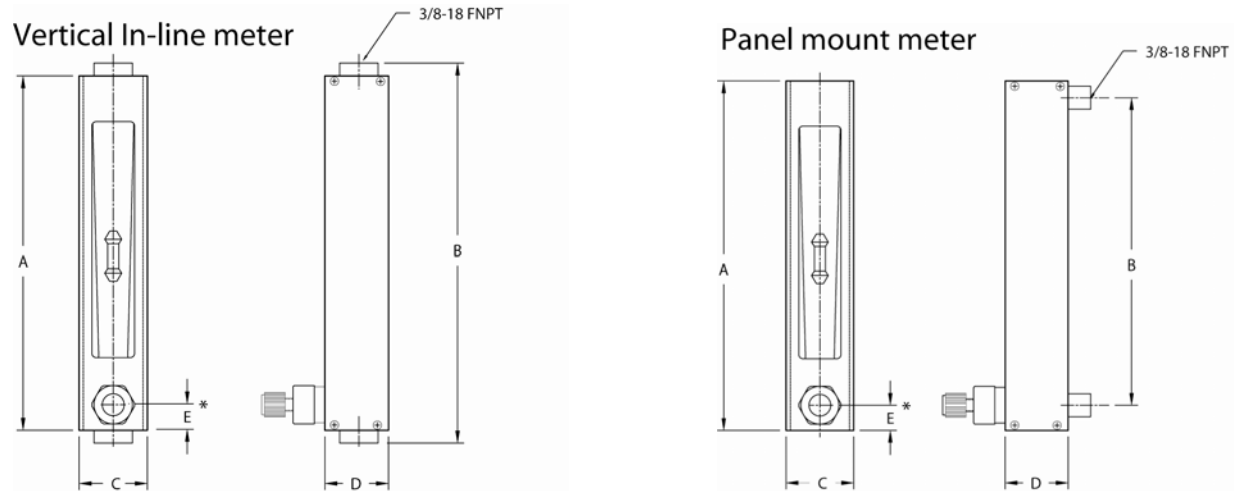

MODEL	INCHES				
	A	B	C	D	E
VERTICAL IN LINE					
VI(B,S)4-VA	10.375	11.125	2.000	1.875	0.750
VI(B,S)3-VA	9.500	10.250	2.000	1.875	
VIT4-TA	10.375	11.125	2.000	1.875	0.750
VIT3-TA	9.500	10.250	2.000	1.875	
PANEL MOUNT					
VP(B,S)4-VA	10.375	9.469	2.000	1.875	0.453
VP(B,S)3-VA	10.375	9.469	2.000	1.875	
VPT4-TA	11.157	9.551	2.000	1.875	0.803
VPT3-TA	11.157	9.551	2.000	1.875	

\*-VALVE OPTIONAL