

# OPERATING MANUAL

## 6APSD0101

solenoid valve driver





## **CAUTION:**

This product is not intended to be used in life support applications!



## **CAUTION:**

K-Factors at best are only an approximation. K factors should not be used in applications that require accuracy better than +/- 5 to 10%.

DAKOTA® is a registered trademark of Dakota Instruments.

Dakota reserves the right to make changes to information and specifications in this manual without notice.

# TABLE OF CONTENTS

<b>(a) UNPACKING THE 6APSD0101 DRIVER MODULE.....</b>	<b>1</b>
a.1 Inspect Package for External Damage.....	1
a.2 Unpack the Valve Driver Module.....	1
a.3 Returning Merchandise for Repair.....	1
<b>(b) INSTALLATION.....</b>	<b>2</b>
b.1 Electrical Connections.....	2
b.1.1 Valve Connection to 6APSD0101.....	3
b.1.2 Input Reference Signal Connection.....	3
b.1.3 TTL Signal Connection.....	3
b.1.4 Power Connection.....	4
<b>(c) DESCRIPTION.....</b>	<b>4</b>
<b>(d) SPECIFICATIONS.....</b>	<b>4</b>
d.1 CE Compliance.....	5
<b>(e) OPERATING INSTRUCTIONS.....</b>	<b>5</b>
e.1 Preparation.....	5
e.2 Maximum Output Voltage to Valve.....	5
e.3 Set Point Reference Signal.....	6
e.4 TTL, Valve ON/OFF Control.....	6
<b>(f) TROUBLESHOOTING.....</b>	<b>7</b>
f.1 Common Conditions.....	7
f.2 Troubleshooting Guide.....	7
f.3 Technical Assistance.....	8

**APPENDIX 1**      COMPONENT DIAGRAMS

**APPENDIX 2**      DIMENSIONAL DRAWINGS

**APPENDIX 3**      WARRANTY

## **(a) UNPACKING THE 6APSD0101 DRIVER MODULE**

### **a.1 Inspect Package for External Damage**

Your 6APSD0101 Solenoid Valve Driver Module was carefully packed in a sturdy cardboard carton, with anti static cushioning materials to withstand shipping shock. Upon receipt, inspect the package for possible external damage. In case of external damage to the package contact the shipping company immediately.

### **a.2 Unpack the Valve Driver Module**

Open the carton carefully from the top and inspect for any sign of concealed shipping damage. In addition to contacting the shipping carrier please forward a copy of any damage report to your distributor or Dakota directly.

When unpacking the instrument please make sure that you have all the items indicated on the Packing List. Please report any shortages promptly.

### **a.3 Returning Merchandise for Repair**

Please contact the customer service representative of your distributor or Dakota if you purchased your equipment directly, and request a **Return Authorization Number (RAN)**. **Equipment returned without an RAN will not be accepted.** Dakota reserves the right to charge a fee to the customer for equipment returned under warranty claims if the instruments are tested to be free from warranted defects.

Shipping charges are borne by the customer. Meters returned "collect" will not be accepted!

It is mandatory that any equipment returned for servicing be purged and neutralized of any dangerous contents including but not limited to toxic, bacterially infectious, corrosive or radioactive substances. No work shall be performed on a returned product unless the customer submits a fully executed, signed SAFETY CERTIFICATE. Please request form from the Service Manager.

## (b) INSTALLATION



**Caution:** It is the users responsibility to determine if the instrument is appropriate for their OXYGEN application, and for specifying O2 cleaning service if required. Aalborg is not liable for any damage or personal injury, whatsoever, resulting from the use of this instrument for oxygen.

### b.1 Electrical Connections

PIN	FUNCTION
1	Valve, E1
2	Valve, E2
3	Power supply, positive
4	Power supply, common
5	0 to 5 VDC, signal in
6	0 to 5 VDC, common
7	4 to 20 mA, signal in
8	4 to 20 mA, common
9	TTL valve ON/OFF control

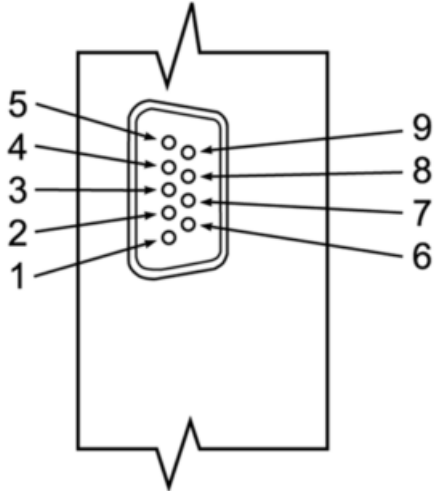

Figure b-1, 9 pin "D" Connector Pinouts for 6APSD0101 Driver Module.



#### Important notes:

In general, "D" Connector numbering patterns are standardized. There are, however, some connectors with nonconforming patterns and the numbering sequence on your mating connector may or may not coincide with the numbering sequence shown in our pin configuration table above. It is imperative that you match the appropriate wires in accordance with the correct sequence regardless of the particular numbers displayed on your mating connector.

Make sure power is OFF when connecting or disconnecting any cables in the system.

The power input is protected by a 1600mA M (medium time lag) resettable fuse. If a shorting condition or polarity reversal occurs, the fuse will cut power to the valve driver circuit. Disconnect the power to the unit, remove the faulty condition, and reconnect the power. The fuse will reset once the faulty condition has been removed.

Use of the 6APSD0101 valve driver in a manner other than that specified in this manual or in writing from Dakota, may impair the protection provided by the equipment.

### b.1.1 Valve Connection to 6APSD0101

Connect the two valve solenoid lead wires (E1 and E2) to pins 1 and 2 of the 9 pin "D" connector. There is no polarity on these connections.

### b.1.2 Input Reference Signal Connection

Connect the desired analog reference signal input (0 to 5 VDC or 4 to 20 mA) to the appropriate pin locations on the 9 pin "D" connector of the 6APSD0101. The 6APSD0101 will recognize automatically which signal is being provided. If both are connected, the 6APSD0101 will give priority to the 4 to 20 mA signal when that signal is greater than 2 mA.

- (a) When using the 0 to 5 VDC reference signal, connect the POSITIVE side of the reference to pin 5, and the NEGATIVE (ground) to pin 6 on the 9 pin "D" connector.
- (b) When using the 4 to 20 mA reference signal, connect the POSITIVE side of the reference to pin 7, and the NEGATIVE (ground) to pin 8 on the 9 pin "D" connector.

For optional RS232 or IEEE488 interfaces please contact your distributor or Dakota.



The NEGATIVE (ground) side of the reference signal inputs is internally connected on the printed circuit board to power ground.

### b.1.3 TTL Signal Connection

The TTL valve ON/OFF control feature is not required for the device to function. Use of this SAFETY feature allows for complete de energizing of the solenoid valve to help ensure valve closure. If this feature is not used, a continuous supply of nominal power will be supplied to the solenoid valve.

When left unconnected on the 9 pin "D" connector, the device will default to the "HIGH" setting in accordance with the selected position of the jumper. The factory default setting is LOW (0 VDC) = OFF and HIGH (5 VDC) = ON.

Jumper Setting (position)	TTL LOW (0 VDC)	TTL HIGH (5 VDC)
4	OFF	ON
5	ON	OFF

Table I TTL Signal Selection

To reverse this configuration, remove the square cap on the back of the 6APSD0101 (see figure e-1). The 4th and 5th position determines the TTL logic configuration. The factory default setting is set with the jumper on position 4. Moving this jumper to position 5 will yield the reverse configuration [LOW (0 VDC) = ON and HIGH (5 VDC) = OFF] (see Table I).

Always make sure that only one jumper is ever applied at any given time to either position 4 or 5. Connecting both at the same time may result in damage to the electronics, and improper control.

#### **b.1.4 Power Connection**

With the DC power supply source OFF, connect the power to the DC power jack OR the 9 pin "D" connector.



**DO NOT CONNECT POWER TO BOTH CONNECTION POINTS AT THE SAME TIME.** This may result in permanent damage to the power supplies and the 6APSD0101.

#### **(c) DESCRIPTION**

The 6APSD0101 solenoid driver module is designed to regulate the power supplied to the proportional solenoid valve (PSV) based on a reference signal. A 0 to 5 VDC or 4 to 20 mA analog set point signal input is used as a reference to proportionally control the output power to the PSV valve. By increasing or decreasing this analog reference signal, the PSV valve volume of gases or liquids processed increases or decreases respectively.

#### **(d) SPECIFICATIONS**

**Environmental (per IEC 664):** Installation Level II; Pollution Degree II.

**Connection:** 9 pin male "D" connector for input/output signals.

**Power Input:** +12 to 30 VDC; 1A @ 12 VDC, 0.5A @ 24 VDC via 9 pin "D" connector or DC power jack (center positive).

**Input Signal:** AUTO SELECT feature allows circuit to recognize which analog input reference (0 to 5 VDC or 4 to 20 mA) signal is received.

For optional RS232 or IEEE488 interfaces please contact your distributor or Dakota.

**TTL ON/OFF:** Jumper selectable LOW (0 VDC) OFF – HIGH (5 VDC) ON [default setting] or reverse, to select valve ON/OFF status.

**Valve Output Power:** Jumper selectable to +15, +22, and +29 VDC with adjacent potentiometer to obtain  $\pm 2$  VDC [default setting 22 VDC].

**Fuse Rating:** internal resettable 1.6A fuse protects the electronics on the power input.

**Polarity Protection:** internal rectifier circuit protects from reversed polarity on the power input.

**Operating Temperature:** 32 °F (0 °C) to 122 °F (50 °C).

## d.1 CE Compliance

Any model 6APSD0101 bearing a CE marking on it, is in compliance with the below stated test standards currently accepted.

EMC Compliance with 89/336/EEC as amended;  
Emission Standard: EN 55011:1991, Group 1, Class A  
Immunity Standard: EN 55082 2:1995

## (e) OPERATING INSTRUCTIONS

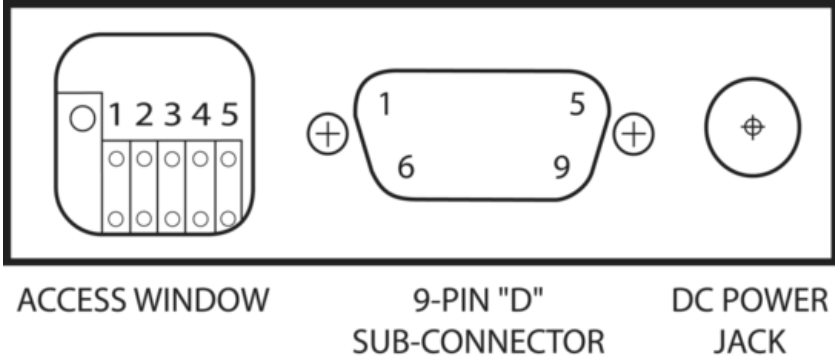

**CAUTION:** If the valve is left in the active mode for an extended period of time, it may become warm or even hot to the touch. Use care in avoiding direct contact with the valve during operation.

### e.1 Preparation

It is assumed that the 6APSD0101 has been correctly installed as described in section (b). Turn the DC power source ON. A pilot light on the front of the 6APSD0101 will illuminate indicating the device is active.

### e.2 Maximum Output Voltage to Valve

As shown in Figure e-1, remove the square plug of the 6APSD0101 for the access window. Position 1, 2, and 3 on the header block determine the maximum output voltage supplied to the valve. The factory default setting is 22 VDC (position 2).

Jumper Setting (position)	Output Voltage to Valve (VDC)
1	15
2	22
3	29

**Table II** Maximum Valve Output Selection



The maximum output voltage supplied to the valve, can be set/changed in the field. Changing this will allow for optimal use of the input reference signal to output valve voltage based on the specific flow rate and operating pressure applied to the valve.

With the power ON, use Table II and Figure e-1 to make the appropriate changes as necessary. (Note: This procedure may not need to be performed. It is provided as an added feature to further customize your system.) Move the jumper to either position 1, 2, or 3, and use the adjacent potentiometer [P1] to make fine adjustments to the desired output voltage.



Always make sure that only one jumper is ever applied at any given time to either position 1, 2, or 3. Connecting two or more at the same time may result in damage to the electronics, and improper control.

### **e.3 Set Point Reference Signal**

The 6APSD0101 solenoid valve driver in conjunction with the PSV solenoid valve allow the user to set the flow to any desired flow rate within the range of the particular model installed. The PSV solenoid valve is normally closed when no power is applied.

The set point input responds to an analog 0 to 5 VDC or 4 to 20 mA reference signal. Use this reference signal via the 6APSD0101 valve driver to set the flow rate of the PSV solenoid valve.

### **e.4 TTL, Valve ON/OFF Control**

It may, at times, be desirable to set the flow and maintain that setting while being able to turn the flow control valve off and on again. This can be accomplished by applying a (TTL compatible) high and low signal of +5 VDC and 0 VDC to pin 9 on the 9 pin "D" connector. The factory default configuration is set so that when 0 VDC (LOW) signal is applied, the solenoid valve is not powered and therefore will remain normally closed. Conversely, a +5 VDC (HIGH) signal applied will allow the solenoid valve to remain active. The solenoid valve will remain active when the VALVE OFF pin remains "floating". (To reverse this configuration, see section b.1.3)

Toggleing the HIGH/LOW signal on and off will allow for activating and deactivating the solenoid valve. Remember: If the TTL signal line is connected, the valve will only function if the appropriate logic input is applied.

## **(f) TROUBLESHOOTING**

### **f.1 Common Conditions**

Your Solenoid Valve Driver Module was thoroughly checked at numerous quality control points during and after manufacturing and assembly operations.

It was carefully packed to prevent damage during shipment. Should you feel that the instrument is not functioning properly please check for the following common conditions first:

Are all cables connected correctly?

Is the power supply correctly selected according to requirements?

Were the connector pinouts matched properly? When interchanging with other manufacturers' equipment, cables and connectors must be carefully wired for correct pin configurations.

### **f.2 Troubleshooting Guide**

<b>INDICATION</b>	<b>LIKELY REASON</b>	<b>REMEDY</b>
no power to valve	power supply off	check connection of power supply
	power supply problem	disconnect GFM transducer from power supply; remove the shorting condition or check polarities; fuse resets automatically
	pc board defective	check power supply for appropriate output
no response to set point	inadequate gas pressure	return to factory for replacement
	cable or connector malfunction	apply appropriate gas pressure
	cable or connector malfunction	check cables and all connections or replace
	set point is too low (<2% of full scale)	re adjust set point
	valve adjustment wrong	re adjust valve
	pc board defective	return to factory for replacement

<b>INDICATION</b>	<b>LIKELY REASON</b>	<b>REMEDY</b>
valve does not work in "active" position	incorrect valve adjustment	re adjust valve
	pc board defect	return to factory for replacement
	cable or connector malfunction	check cable and connectors or replace
	differential pressure too high	decrease pressure to correct level
	insufficient inlet pressure	adjust appropriately
valve does not work in close position	incorrect valve adjustment	re adjust valve
	pc board defect	return to factory for replacement
	cable or connector malfunction	check cable and connectors or replace
	orifice obstructed	disassemble to remove impediments or return to factory

For best results it is recommended that instruments are returned to the factory for servicing. See section a.3 for return procedures.

### **f.3 Technical Assistance**

Dakota Instruments will provide technical assistance over the phone to qualified repair personnel. Please call our Technical Assistance at 845-770-3200. Please have your Serial Number and Model Number ready when you call.

# APPENDIX 1

## COMPONENTS DIAGRAM

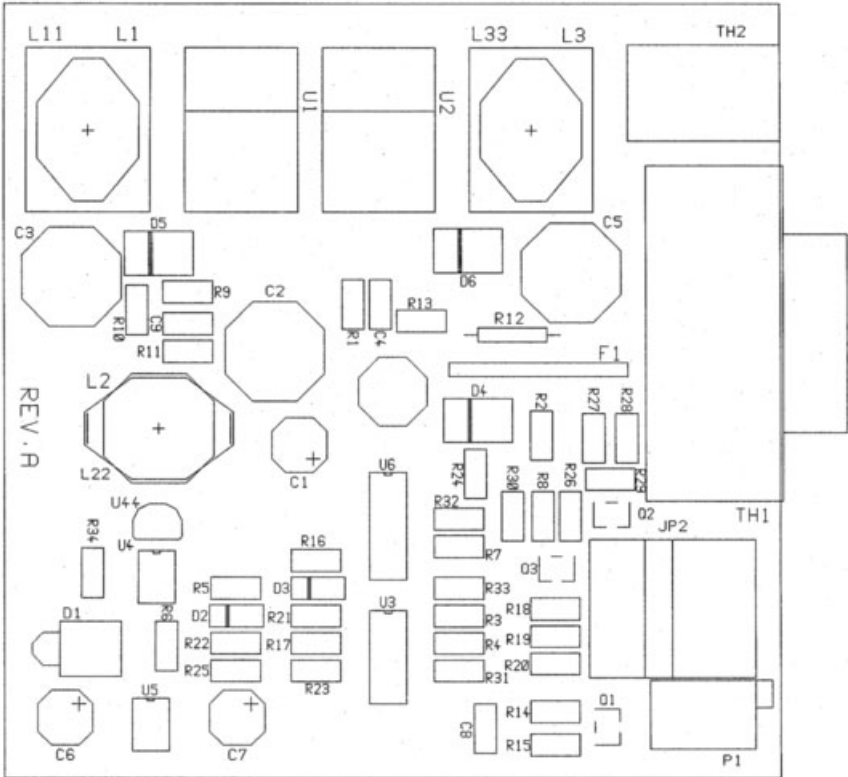

6APSD0101 Solenoid Valve Driver PC Board

**APPENDIX 2**  
**DIMENSIONAL DRAWINGS**

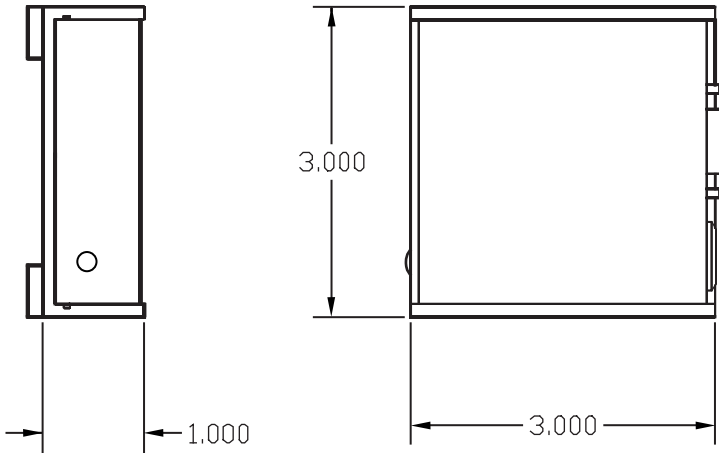

6APSD0101 Solenoid Valve Driver Module

NOTES: Dakota reserves the right to change designs and dimensions at its sole discretion at any time without notice. For certified dimensions please contact Dakota.

## APPENDIX 3

### WARRANTY

Dakota® Mass Flow Systems are warranted against parts and workmanship for a period of one year from the date of purchase. Calibrations are warranted for up to six months after date of purchase, provided calibration seals have not been tampered with. It is assumed that equipment selected by the customer is constructed of materials compatible with gases used. Proper selection is the responsibility of the customer. It is understood that gases under pressure present inherent hazards to the user and to equipment, and it is deemed the responsibility of the customer that only operators with basic knowledge of the equipment and its limitations are permitted to control and operate the equipment covered by this warranty. Anything to the contrary will automatically void the liability of Dakota® and the provisions of this warranty. Defective products will be repaired or replaced solely at the discretion of Dakota® at no charge. Shipping charges are borne by the customer. This warranty is void if the equipment is damaged by accident or misuse, or has been repaired or modified by anyone other than Dakota® or factory authorized service facility. This warranty defines the obligation of Dakota® and no other warranties expressed or implied are recognized.

NOTE: Follow Return Procedures In Section a.3.





20 Corporate Drive  
Orangeburg NY 10962 USA  
Website: <http://dakotainstruments.com>  
E-mail: [info@dakotainstruments.com](mailto:info@dakotainstruments.com)  
Toll Free USA and Canada: 1(800) 879-7713  
Tel. 1+(845) 770-3200 Fax. 1+(845) 770-3210

---