



MASS FLOW METERS

A low cost solution to thermal mass flow metering for gases is presented by Dakota's mass flow meter line.

The mass flow meter design combines the convenience and accuracy of conventional mass flow devices with low costs previously unattainable.

Each of these meters incorporate an advanced straight tube sensor in conjunction with flow passage elements constructed of aluminum and brass for non-corrosive gases or 316 stainless steel for corrosive applications.

GENERAL DESCRIPTION

Compact, self contained Mass Flow Meters are designed to read flow rates of gases. The rugged design coupled with instrumentation grade accuracy provides versatile and economical means of flow control.

Aluminum or stainless steel models with readout options of either engineering units (standard) or 0 to 100 percent displays are available.

The mechanical layout of the design includes an LCD readout built into the top of the transducer. This readout module is tiltable over 90 degrees to provide optimal reading comfort. It is connected to the transducer by a standard modular plug, and is also readily removable for remote reading installations. Transducers without LCD readout are offered for OEM applications.

Mass flow meters are available with flow ranges from 10 sccm to 1000 sL/min N₂. Gases are connected by means of 1/4", 3/8", 1/2" compression fittings and 3/4" FNPT fittings. Optional fittings are available. These controllers may be used as bench top units or mounted by means of screws in the base.

* The selection of materials of construction, is the responsibility of the customer. The company accepts no liability.

DIMENSIONS (not including fittings)

GM1	Models up to 15 sL/min: 3"W x 5 1/2"H x 1"D
GM3 /GM4	30 to 100 sL/min models: 3 5/8"W x 6"H x 1 1/4"D
GM5	200 sL/min models: 12"W x 9"H x 2 1/2"D
GM6	500 sL/min models: 12"W x 10"H x 3 1/2"D
GM7	1000 sL/min models: 12"W x 11 1/2"H x 5"D

MODEL	FLOW RATE [std liters/min]	MAXIMUM PRESSURE DROP		
		[mm H ₂ O]	[psid]	[mbar]
GM1	up to 10	25	0.04	2.5
GM3	20	300	0.44	30
	30	800	1.18	81
	40	1480	2.18	150
	50	2200	3.23	223
GM4	60	3100	4.56	314
	80	4422	6.5	448
	100	5500	8.08	557
GM5	200	272	4.0	28
GM6	500	340	5.0	34
GM7	1000	612	9.0	62

*SPECIFICATIONS

ACCURACY:	GM 1, 3 and 4: ±1.0% of full scale. GM 5, 6 and 7: ±1.5% of full scale. OPTIONAL ENHANCED ACCURACY: ±1.0% of full scale.
CALIBRATIONS:	Performed at standard conditions [14.7 psia (101.4 kPa) and 70 °F (21.1 °C)] unless otherwise requested.
REPEATABILITY:	±0.25% of full scale.
RESPONSE TIME:	Generally 2 seconds to within ±2% of actual flow rate over 25 to 100% of full scale.
TEMPERATURE COEFFICIENT:	0.15% of full scale / °C.
PRESSURE COEFFICIENT:	0.01% of full scale / psi (0.07 bar).
MAXIMUM PRESSURE DROP:	See Table 3.
GAS and AMBIENT TEMP.:	32 °F to 122 °F (0 °C to 50 °C). 14 °F to 122 °F (-10 °C to 50 °C) - Dry gases only.
OUTPUT SIGNALS:	Linear 0-5 Vdc. 1000 ohms min. load impedance and 4-20 mA 0-500 Ohms loop resistance.
TRANSDUCER INPUT POWER:	Universal +12 to +26 VDC, 200 mA maximum.
TIME CONSTANT:	800 ms.
GAS PRESSURE:	1000 psig (70 bars) maximum GM 1, 3, 4. 20 psig (1.4 bars) optimum. 500 psig (34.5 bars) GM 5, 6, 7. 20 psig (1.4 bars) optimum.
** MATERIALS IN FLUID CONTACT:	a. Aluminum models GM Series: anodized aluminum, 316 stainless steel, brass and Viton® O-rings. b. Stainless steel models GM1S, 3S,4S, 5S, 6S and 7S: 316 stainless steel and Viton® O-rings. Optional O-rings: Buna®, EPR and Kalrez®.
ATTITUDE SENSITIVITY:	No greater than +15 degree rotation from horizontal to vertical; standard calibration is in horizontal position.
CONNECTIONS:	GFC 1: 1/4" compression fittings. Optional: 6mm, 3/8" and 1/8" compression fittings or 1/4" VCR®. GFC 3: 1/4" compression fittings. Optional: 6mm and 3/8" compression fittings or 1/4" VCR®. GM 4: 3/8" compression fittings. GM 5: 3/8" compression fittings. GM 6: 1/2" compression fittings. GM 7: 3/4" FNPT fittings or 3/4" compression fittings.
LEAK INTEGRITY:	1 x 10 ⁻⁹ smL/sec of helium maximum to the outside environment.
CE COMPLIANT:	EN 55011 class 1, class B; EN50082-1.

MASS FLOW METERS

Aluminum and Stainless Mass Flow Meters



DESIGN FEATURES

- ✓ Rigid metallic construction.
- ✓ Maximum pressure of 1000 psig (70 bars) for GM1, GM3, GM4 models. 500 psig for GM5, GM6 and GM7.
- ✓ Leak integrity 1×10^{-9} of helium.
- ✓ NIST traceable certification.
- ✓ Built-in tiltable LCD readout.
- ✓ 0-5 Vdc and 4-20 mA signals.
- ✓ Circuit protection.
- ✓ Can be used as a portable device.
- ✓ Engineering units or 0 to 100% displays.
- ✓ Totalizer option.

Flow rates are unaffected by temperature and pressure variations within stated limitations.

PRINCIPLES OF OPERATION

Metered gases are divided into two laminar flow paths, one through the primary flow conduit, and the other through a capillary sensor tube. Both flow conduits are designed to ensure laminar flows and therefore the ratio of their flow rates is constant.

Two precision temperature sensing windings on the sensor tube are heated, and when flow takes place, gas carries heat from the upstream to the downstream windings. The resultant temperature differential is proportional to the change in resistance of the sensor windings.

Output signals of 0 to 5Vdc and 4 to 20mA are generated indicating mass molecular based flow rates of the metered gas.

Flow rates are unaffected by temperature and pressure variations within stated limitations.

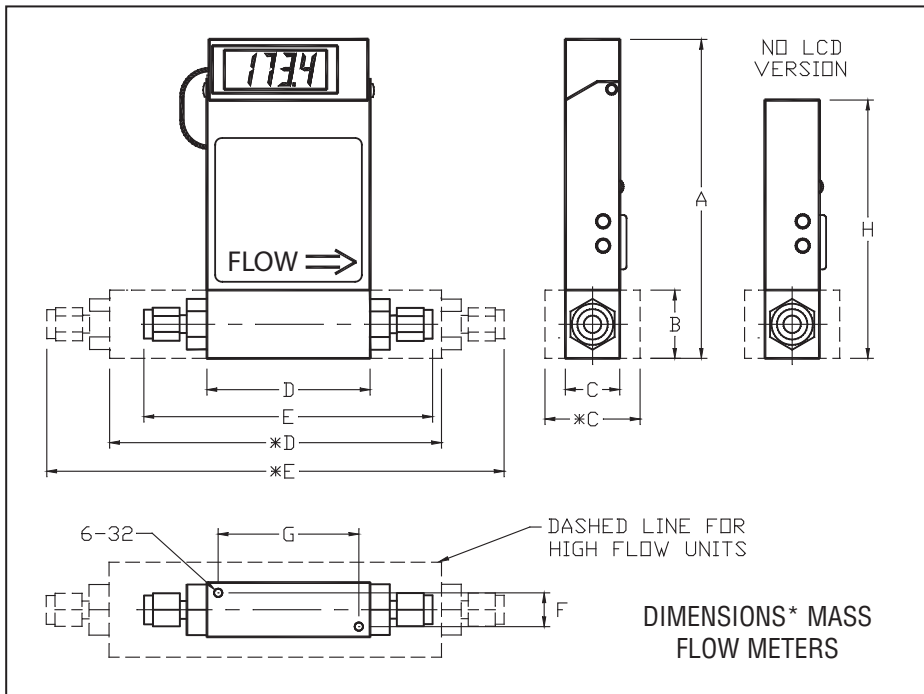

MODEL	CONNECTION Compression Fitting (except model GM7)	DIMENSION (INCH)								
		LCD VERSION								NO LCD
		A	B	C/*C	D/*D	E/*E	F	G	H	
GM1	1/4" Tube O Diameter	5.60	1.00	1.00	3.00	5.02	0.69	2.68	4.50	
GM3	1/4" Tube O Diameter	5.98	1.37	1.25	4.13	6.15	0.69	2.68	4.88	
GM4	3/8" Tube O Diameter	5.98	1.37	1.25	4.13	6.27	0.69	2.68	4.88	
GM5	3/8" Tube O Diameter	6.60	2.00	1.75	6.69	8.83	0.99	4.68	5.50	
GM6	1/2" Tube O Diameter	7.60	3.00	3.00	7.25	9.67	1.69	4.68	6.50	
GM7	3/4" NPT Female	8.60	4.00	4.00	7.30	-	1.69	4.68	7.50	

GM Mass Flow Models for Air
Optional 4-20 mA - No charge
Other Gases Available
Consult Dakota

TABLE 36-1 GM1 LOW RANGE MASS FLOW METER			
AIR			
MODEL NO.	FLOW RATE	OUTPUT	PRICE
Aluminum With No Display			
6AGM1AN5-01AB	0 - 10 mL/min	0-5 VDC	\$431.00
6AGM1AN5-02AB	0 - 20 mL/min		
6AGM1AN5-03AB	0 - 50 mL/min		
6AGM1AN5-04AB	0 - 100 mL/min		
6AGM1AN5-05AB	0 - 200 mL/min		
6AGM1AN5-06AB	0 - 500 mL/min		
6AGM1AN5-07AB	0 - 1 L/min		
6AGM1AN5-08AB	0 - 2 L/min		
6AGM1AN5-09AB	0 - 5 L/min		
6AGM1AN5-10AB	0 - 10 L/min		
Aluminum With Display			
6AGM1AL5-01AB	0 - 10 mL/min	0-5 VDC	\$511.00
6AGM1AL5-02AB	0 - 20 mL/min		
6AGM1AL5-03AB	0 - 50 mL/min		
6AGM1AL5-04AB	0 - 100 mL/min		
6AGM1AL5-05AB	0 - 200 mL/min		
6AGM1AL5-06AB	0 - 500 mL/min		
6AGM1AL5-07AB	0 - 1 L/min		
6AGM1AL5-08AB	0 - 2 L/min		
6AGM1AL5-09AB	0 - 5 L/min		
6AGM1AL5-10AB	0 - 10 L/min		
Stainless Steel with No Display			
6AGM1SN5-01AB	0 - 10 mL/min	0-5 VDC	\$770.00
6AGM1SN5-02AB	0 - 20 mL/min		
6AGM1SN5-03AB	0 - 50 mL/min		
6AGM1SN5-04AB	0 - 100 mL/min		
6AGM1SN5-05AB	0 - 200 mL/min		
6AGM1SN5-06AB	0 - 500 mL/min		
6AGM1SN5-07AB	0 - 1 L/min		
6AGM1SN5-08AB	0 - 2 L/min		
6AGM1SN5-09AB	0 - 5 L/min		
6AGM1SN5-10AB	0 - 10 L/min		
Stainless Steel with Display			
6AGM1SL5-01AB	0 - 10 mL/min	0-5 VDC	\$851.00
6AGM1SL5-02AB	0 - 20 mL/min		
6AGM1SL5-03AB	0 - 50 mL/min		
6AGM1SL5-04AB	0 - 100 mL/min		
6AGM1SL5-05AB	0 - 200 mL/min		
6AGM1SL5-06AB	0 - 500 mL/min		
6AGM1SL5-07AB	0 - 1 L/min		
6AGM1SL5-08AB	0 - 2 L/min		
6AGM1SL5-09AB	0 - 5 L/min		
6AGM1SL5-10AB	0 - 10 L/min		

TABLE 36-2 GM4 MEDIUM RANGE MASS FLOW METER			
AIR			
MODEL NO.	FLOW RATE	OUTPUT	PRICE
Aluminum with No Display			
6AGM4AN5-40AB	0 - 60 L/min	0-5 VDC	\$771.00
6AGM4AN5-41AB	0 - 80 L/min		
6AGM4AN5-42AB	0 - 100 L/min		
Aluminum with Display			
6AGM4AL5-40AB	0 - 60 L/min	0-5 VDC	\$805.00
6AGM4AL5-41AB	0 - 80 L/min		
6AGM4AL5-42AB	0 - 100 L/min		
Stainless Steel with No Display			
6AGM4SN5-40AB	0 - 60 L/min	0-5 VDC	\$1196.00
6AGM4SN5-41AB	0 - 80 L/min		
6AGM4SN5-42AB	0 - 100 L/min		
Stainless Steel with Display			
6AGM4SL5-40AB	0 - 60 L/min	0-5 VDC	\$1236.00
6AGM4SL5-41AB	0 - 80 L/min		
6AGM4SL5-42AB	0 - 100 L/min		

TABLE 36-3 GM3 MEDIUM RANGE MASS FLOW METER			
AIR			
MODEL NO.	FLOW RATE	OUTPUT	PRICE
Aluminum with No Display			
6AGM3AN5-29AB	0 - 15 L/min	0-5 VDC	\$575.00
6AGM3AN5-30AB	0 - 20 L/min		
6AGM3AN5-31AB	0 - 30 L/min		
6AGM3AN5-32AB	0 - 40 L/min		
6AGM3AN5-33AB	0 - 50 L/min		
Aluminum with Display			
6AGM3AL5-29AB	0 - 15 L/min	0-5 VDC	\$655.00
6AGM3AL5-30AB	0 - 20 L/min		
6AGM3AL5-31AB	0 - 30 L/min		
6AGM3AL5-32AB	0 - 40 L/min		
6AGM3AL5-33AB	0 - 50 L/min		
Stainless Steel with No Display			
6AGM3SN5-29AB	0 - 15 L/min	0-5 VDC	\$1000.00
6AGM3SN5-30AB	0 - 20 L/min		
6AGM3SN5-31AB	0 - 30 L/min		
6AGM3SN5-32AB	0 - 40 L/min		
6AGM3SN5-33AB	0 - 50 L/min		
Stainless Steel with Display			
6AGM3SL5-29AB	0 - 15 L/min	0-5 VDC	\$1081.00
6AGM3SL5-30AB	0 - 20 L/min		
6AGM3SL5-31AB	0 - 30 L/min		
6AGM3SL5-32AB	0 - 40 L/min		
6AGM3SL5-33AB	0 - 50 L/min		

TABLE 36-4 GM5 HIGH RANGE MASS FLOW METER			
AIR			
MODEL NO.	FLOW RATE	OUTPUT	PRICE
Aluminum with No Display			
6AGM5AN5-50AB	0 - 200 L/min	0-5 VDC	\$895.00
Aluminum with Display			
6AGM5AL5-50AB	0 - 200 L/min	0-5 VDC	\$975.00
Stainless Steel with No Display			
6AGM5SN5-50AB	0 - 200 L/min	0-5 VDC	\$1420.00
Stainless Steel with Display			
6AGM5SL5-50AB	0 - 200 L/min	0-5 VDC	\$1500.00

TABLE 36-5 GM6 HIGH RANGE MASS FLOW METER			
AIR			
MODEL NO.	FLOW RATE	OUTPUT	PRICE
Aluminum with No Display			
6AGM6AN5-60AB	0 - 500 L/min	0-5 VDC	\$960.00
Aluminum with Display			
6AGM6AL5-60AB	0 - 500 L/min	0-5 VDC	\$1040.00
Stainless Steel with No Display			
6AGM6SN5-60AB	0 - 500 L/min	0-5 VDC	\$1520.00
Stainless Steel with Display			
6AGM6SL5-60AB	0 - 200 L/min	0-5 VDC	\$1600.00

TABLE 36-6 GM7 HIGH RANGE MASS FLOW METER			
AIR			
MODEL NO.	FLOW RATE	OUTPUT	PRICE
Aluminum with No Display			
6AGM7AN5-70AB	0 - 1000 L/min	0-5 VDC	\$1090.00
Aluminum with Display			
6AGM7AL5-70AB	0 - 1000 L/min	0-5 VDC	\$1170.00
Stainless Steel with No Display			
6AGM7SN5-70AB	0 - 1000 L/min	0-5 VDC	\$1720.00
Stainless Steel with Display			
6AGM7SL5-70AB	0 - 1000 L/min	0-5 VDC	\$1800.00

All models come with NIST traceable calibration.

Optional Accessories see page 48

MASS FLOW METERS

GM Mass Flow Models for Nitrogen
Optional 4-20 mA - No charge
Other Gases Available
Consult Dakota

TABLE 37-1 GM1 LOW RANGE MASS FLOW METER			
NITROGEN			
MODEL NO.	FLOW RATE	OUTPUT	PRICE
Aluminum With No Display			
6AGM1AN5-01NC	0 - 10 mL/min	0-5 VDC	\$431.00
6AGM1AN5-02NC	0 - 20 mL/min		
6AGM1AN5-03NC	0 - 50 mL/min		
6AGM1AN5-04NC	0 - 100 mL/min		
6AGM1AN5-05NC	0 - 200 mL/min		
6AGM1AN5-06NC	0 - 500 mL/min		
6AGM1AN5-07NC	0 - 1 L/min		
6AGM1AN5-08NC	0 - 2 L/min		
6AGM1AN5-09NC	0 - 5 L/min		
6AGM1AN5-10NC	0 - 10 L/min		
Aluminum With Display			
6AGM1AL5-01NC	0 - 10 mL/min	0-5 VDC	\$511.00
6AGM1AL5-02NC	0 - 20 mL/min		
6AGM1AL5-03NC	0 - 50 mL/min		
6AGM1AL5-04NC	0 - 100 mL/min		
6AGM1AL5-05NC	0 - 200 mL/min		
6AGM1AL5-06NC	0 - 500 mL/min		
6AGM1AL5-07NC	0 - 1 L/min		
6AGM1AL5-08NC	0 - 2 L/min		
6AGM1AL5-09NC	0 - 5 L/min		
6AGM1AL5-10NC	0 - 10 L/min		
Stainless Steel with No Display			
6AGM1SN5-01NC	0 - 10 mL/min	0-5 VDC	\$770.00
6AGM1SN5-02NC	0 - 20 mL/min		
6AGM1SN5-03NC	0 - 50 mL/min		
6AGM1SN5-04NC	0 - 100 mL/min		
6AGM1SN5-05NC	0 - 200 mL/min		
6AGM1SN5-06NC	0 - 500 mL/min		
6AGM1SN5-07NC	0 - 1 L/min		
6AGM1SN5-08NC	0 - 2 L/min		
6AGM1SN5-09NC	0 - 5 L/min		
6AGM1SN5-10NC	0 - 10 L/min		
Stainless Steel with Display			
6AGM1SL5-01NC	0 - 10 mL/min	0-5 VDC	\$851.00
6AGM1SL5-02NC	0 - 20 mL/min		
6AGM1SL5-03NC	0 - 50 mL/min		
6AGM1SL5-04NC	0 - 100 mL/min		
6AGM1SL5-05NC	0 - 200 mL/min		
6AGM1SL5-06NC	0 - 500 mL/min		
6AGM1SL5-07NC	0 - 1 L/min		
6AGM1SL5-08NC	0 - 2 L/min		
6AGM1SL5-09NC	0 - 5 L/min		
6AGM1SL5-10NC	0 - 10 L/min		

TABLE 37-2 GM3 MEDIUM RANGE MASS FLOW METER			
NITROGEN			
MODEL NO.	FLOW RATE	OUTPUT	PRICE
Aluminum with No Display			
6AGM3AN5-29NC	0 - 15 L/min	0-5 VDC	\$575.00
6AGM3AN5-30NC	0 - 20 L/min		
6AGM3AN5-31NC	0 - 30 L/min		
6AGM3AN5-32NC	0 - 40 L/min		
6AGM3AN5-33NC	0 - 50 L/min		
Aluminum with Display			
6AGM3AL5-29NC	0 - 15 L/min	0-5 VDC	\$655.00
6AGM3AL5-30NC	0 - 20 L/min		
6AGM3AL5-31NC	0 - 30 L/min		
6AGM3AL5-32NC	0 - 40 L/min		
6AGM3AL5-33NC	0 - 50 L/min		
Stainless Steel with No Display			
6AGM3SN5-29NC	0 - 15 L/min	0-5 VDC	\$1000.00
6AGM3SN5-30NC	0 - 20 L/min		
6AGM3SN5-31NC	0 - 30 L/min		
6AGM3SN5-32NC	0 - 40 L/min		
6AGM3SN5-33NC	0 - 50 L/min		
Stainless Steel with Display			
6AGM3SL5-29NC	0 - 15 L/min	0-5 VDC	\$1081.00
6AGM3SL5-30NC	0 - 20 L/min		
6AGM3SL5-31NC	0 - 30 L/min		
6AGM3SL5-32NC	0 - 40 L/min		
6AGM3SL5-33NC	0 - 50 L/min		

TABLE 37-3 GM4 MEDIUM RANGE MASS FLOW METER			
NITROGEN			
MODEL NO.	FLOW RATE	OUTPUT	PRICE
Aluminum with No Display			
6AGM4AN5-40NC	0 - 60 L/min	0-5 VDC	\$771.00
6AGM4AN5-41NC	0 - 80 L/min		
6AGM4AN5-42NC	0 - 100 L/min		
Aluminum with Display			
6AGM4AL5-40NC	0 - 60 L/min	0-5 VDC	\$805.00
6AGM4AL5-41NC	0 - 80 L/min		
6AGM4AL5-42NC	0 - 100 L/min		
Stainless Steel with No Display			
6AGM4SN5-40NC	0 - 60 L/min	0-5 VDC	\$1196.00
6AGM4SN5-41NC	0 - 80 L/min		
6AGM4SN5-42NC	0 - 100 L/min		
Stainless Steel with Display			
6AGM4SL5-40NC	0 - 60 L/min	0-5 VDC	\$1236.00
6AGM4SL5-41NC	0 - 80 L/min		
6AGM4SL5-42NC	0 - 100 L/min		

TABLE 37-4 GM5 HIGH RANGE MASS FLOW METER			
NITROGEN			
MODEL NO.	FLOW RATE	OUTPUT	PRICE
Aluminum with No Display			
6AGM5AN5-50NC	0 - 200 L/min	0-5 VDC	\$895.00
Aluminum with Display			
6AGM5AL5-50NC	0 - 200 L/min	0-5 VDC	\$975.00
Stainless Steel with No Display			
6AGM5SN5-50NC	0 - 200 L/min	0-5 VDC	\$1420.00
Stainless Steel with Display			
6AGM5SL5-50NC	0 - 200 L/min	0-5 VDC	\$1500.00

TABLE 37-5 GM6 HIGH RANGE MASS FLOW METER			
NITROGEN			
MODEL NO.	FLOW RATE	OUTPUT	PRICE
Aluminum with No Display			
6AGM6AN5-60NC	0 - 500 L/min	0-5 VDC	\$960.00
Aluminum with Display			
6AGM6AL5-60NC	0 - 500 L/min	0-5 VDC	\$1040.00
Stainless Steel with No Display			
6AGM6SN5-60NC	0 - 500 L/min	0-5 VDC	\$1520.00
Stainless Steel with Display			
6AGM6SL5-60NC	0 - 200 L/min	0-5 VDC	\$1600.00

TABLE 37-6 GM7 HIGH RANGE MASS FLOW METER			
NITROGEN			
MODEL NO.	FLOW RATE	OUTPUT	PRICE
Aluminum with No Display			
6AGM7AN5-70NC	0 - 1000 L/min	0-5 VDC	\$1090.00
Aluminum with Display			
6AGM7AL5-70NC	0 - 1000 L/min	0-5 VDC	\$1170.00
Stainless Steel with No Display			
6AGM7SN5-70NC	0 - 1000 L/min	0-5 VDC	\$1720.00
Stainless Steel with Display			
6AGM7SL5-70NC	0 - 1000 L/min	0-5 VDC	\$1800.00

Optional Accessories see page 48

GM Mass Flow Models for Oxygen
Optional 4-20 mA - No charge
Other Gases Available
Consult Dakota

TABLE 38-1, GM1 LOW RANGE MASS FLOW METER			
OXYGEN			
MODEL NO.	FLOW RATE	OUTPUT	PRICE
Aluminum With No Display			
6AGM1AN5-010B	0 - 10 mL/min	0-5 VDC	\$431.00
6AGM1AN5-020B	0 - 20 mL/min		
6AGM1AN5-030B	0 - 50 mL/min		
6AGM1AN5-040B	0 - 100 mL/min		
6AGM1AN5-050B	0 - 200 mL/min		
6AGM1AN5-060B	0 - 500 mL/min		
6AGM1AN5-070B	0 - 1 L/min		
6AGM1AN5-080B	0 - 2 L/min		
6AGM1AN5-090B	0 - 5 L/min		
6AGM1AN5-100B	0 - 10 L/min		
Aluminum With Display			
6AGM1AL5-010B	0 - 10 mL/min	0-5 VDC	\$511.00
6AGM1AL5-020B	0 - 20 mL/min		
6AGM1AL5-030B	0 - 50 mL/min		
6AGM1AL5-040B	0 - 100 mL/min		
6AGM1AL5-050B	0 - 200 mL/min		
6AGM1AL5-060B	0 - 500 mL/min		
6AGM1AL5-070B	0 - 1 L/min		
6AGM1AL5-080B	0 - 2 L/min		
6AGM1AL5-090B	0 - 5 L/min		
6AGM1AL5-100B	0 - 10 L/min		
Stainless Steel with No Display			
6AGM1SN5-010B	0 - 10 mL/min	0-5 VDC	\$770.00
6AGM1SN5-020B	0 - 20 mL/min		
6AGM1SN5-030B	0 - 50 mL/min		
6AGM1SN5-040B	0 - 100 mL/min		
6AGM1SN5-050B	0 - 200 mL/min		
6AGM1SN5-060B	0 - 500 mL/min		
6AGM1SN5-070B	0 - 1 L/min		
6AGM1SN5-080B	0 - 2 L/min		
6AGM1SN5-090B	0 - 5 L/min		
6AGM1SN5-100B	0 - 10 L/min		
Stainless Steel with Display			
6AGM1SL5-010B	0 - 10 mL/min	0-5 VDC	\$851.00
6AGM1SL5-020B	0 - 20 mL/min		
6AGM1SL5-030B	0 - 50 mL/min		
6AGM1SL5-040B	0 - 100 mL/min		
6AGM1SL5-050B	0 - 200 mL/min		
6AGM1SL5-060B	0 - 500 mL/min		
6AGM1SL5-070B	0 - 1 L/min		
6AGM1SL5-080B	0 - 2 L/min		
6AGM1SL5-090B	0 - 5 L/min		
6AGM1SL5-100B	0 - 10 L/min		

TABLE 38-2 GM3 MEDIUM RANGE MASS FLOW METER			
OXYGEN			
MODEL NO.	FLOW RATE	OUTPUT	PRICE
Aluminum with No Display			
6AGM3AN5-290B	0 - 15 L/min	0-5 VDC	\$575.00
6AGM3AN5-300B	0 - 20 L/min		
6AGM3AN5-310B	0 - 30 L/min		
6AGM3AN5-320B	0 - 40 L/min		
6AGM3AN5-330B	0 - 50 L/min		
Aluminum with Display			
6AGM3AL5-290B	0 - 15 L/min	0-5 VDC	\$655.00
6AGM3AL5-300B	0 - 20 L/min		
6AGM3AL5-310B	0 - 30 L/min		
6AGM3AL5-320B	0 - 40 L/min		
6AGM3AL5-330B	0 - 50 L/min		
Stainless Steel with No Display			
6AGM3SN5-290B	0 - 15 L/min	0-5 VDC	\$1000.00
6AGM3SN5-300B	0 - 20 L/min		
6AGM3SN5-310B	0 - 30 L/min		
6AGM3SN5-320B	0 - 40 L/min		
6AGM3SN5-330B	0 - 50 L/min		
Stainless Steel with Display			
6AGM3SL5-290B	0 - 15 L/min	0-5 VDC	\$1081.00
6AGM3SL5-300B	0 - 20 L/min		
6AGM3SL5-310B	0 - 30 L/min		
6AGM3SL5-320B	0 - 40 L/min		
6AGM3SL5-330B	0 - 50 L/min		

TABLE 38-3 GM4 MEDIUM RANGE MASS FLOW METER			
OXYGEN			
MODEL NO.	FLOW RATE	OUTPUT	PRICE
Aluminum with No Display			
6AGM4AN5-400B	0 - 60 L/min	0-5 VDC	\$771.00
6AGM4AN5-410B	0 - 80 L/min		
6AGM4AN5-420B	0 - 100 L/min		
Aluminum with Display			
6AGM4AL5-400B	0 - 60 L/min	0-5 VDC	\$805.00
6AGM4AL5-410B	0 - 80 L/min		
6AGM4AL5-420B	0 - 100 L/min		
Stainless Steel with No Display			
6AGM4SN5-400B	0 - 60 L/min	0-5 VDC	\$1196.00
6AGM4SN5-410B	0 - 80 L/min		
6AGM4SN5-420B	0 - 100 L/min		
Stainless Steel with Display			
6AGM4SL5-400B	0 - 60 L/min	0-5 VDC	\$1236.00
6AGM4SL5-410B	0 - 80 L/min		
6AGM4SL5-420B	0 - 100 L/min		

TABLE 38-4 GM5 HIGH RANGE MASS FLOW METER			
OXYGEN			
MODEL NO.	FLOW RATE	OUTPUT	PRICE
Aluminum with No Display			
6AGM5AN5-500B	0 - 200 L/min	0-5 VDC	\$895.00
Aluminum with Display			
6AGM5AL5-500B	0 - 200 L/min	0-5 VDC	\$975.00
Stainless Steel with No Display			
6AGM5SN5-500B	0 - 200 L/min	0-5 VDC	\$1420.00
Stainless Steel with Display			
6AGM5SL5-500B	0 - 200 L/min	0-5 VDC	\$1500.00

TABLE 38-5 GM6 HIGH RANGE MASS FLOW METER			
OXYGEN			
MODEL NO.	FLOW RATE	OUTPUT	PRICE
Aluminum with No Display			
6AGM6AN5-600B	0 - 500 L/min	0-5 VDC	\$960.00
Aluminum with Display			
6AGM6AL5-600B	0 - 500 L/min	0-5 VDC	\$1040.00
Stainless Steel with No Display			
6AGM6SN5-600B	0 - 500 L/min	0-5 VDC	\$1520.00
Stainless Steel with Display			
6AGM6SL5-600B	0 - 500 L/min	0-5 VDC	\$1600.00

TABLE 38-6 GM7 HIGH RANGE MASS FLOW METER			
OXYGEN			
MODEL NO.	FLOW RATE	OUTPUT	PRICE
Aluminum with No Display			
6AGM7AN5-70AB	0 - 1000 L/min	0-5 VDC	\$1090.00
Aluminum with Display			
6AGM7AL5-70AB	0 - 1000 L/min	0-5 VDC	\$1170.00
Stainless Steel with No Display			
6AGM7SN5-70AB	0 - 1000 L/min	0-5 VDC	\$1720.00
Stainless Steel with Display			
6AGM7SL5-70AB	0 - 1000 L/min	0-5 VDC	\$1800.00

Optional Accessories see page 48

MASS FLOW METERS

GM Mass Flow Models for Carbon Dioxide
Optional 4-20 mA - No charge
Other Gases Available
Consult Dakota

TABLE 39-1, GM1 LOW RANGE MASS FLOW METER

CARBON DIOXIDE			
MODEL NO.	FLOW RATE	OUTPUT	PRICE
Aluminum With No Display			
6AGM1AN5-01CA	0 - 10 mL/min	0-5 VDC	\$431.00
6AGM1AN5-02CA	0 - 20 mL/min		
6AGM1AN5-03CA	0 - 50 mL/min		
6AGM1AN5-04CA	0 - 100 mL/min		
6AGM1AN5-05CA	0 - 200 mL/min		
6AGM1AN5-06CA	0 - 500 mL/min		
6AGM1AN5-07CA	0 - 1 L/min		
6AGM1AN5-08CA	0 - 2 L/min		
6AGM1AN5-09CA	0 - 5 L/min		
6AGM1AN5-10CA	0 - 10 L/min		
Aluminum With Display			
6AGM1AL5-01CA	0 - 10 mL/min	0-5 VDC	\$511.00
6AGM1AL5-02CA	0 - 20 mL/min		
6AGM1AL5-03CA	0 - 50 mL/min		
6AGM1AL5-04CA	0 - 100 mL/min		
6AGM1AL5-05CA	0 - 200 mL/min		
6AGM1AL5-06CA	0 - 500 mL/min		
6AGM1AL5-07CA	0 - 1 L/min		
6AGM1AL5-08CA	0 - 2 L/min		
6AGM1AL5-09CA	0 - 5 L/min		
6AGM1AL5-10CA	0 - 10 L/min		
Stainless Steel with No Display			
6AGM1SN5-01CA	0 - 10 mL/min	0-5 VDC	\$770.00
6AGM1SN5-02CA	0 - 20 mL/min		
6AGM1SN5-03CA	0 - 50 mL/min		
6AGM1SN5-04CA	0 - 100 mL/min		
6AGM1SN5-05CA	0 - 200 mL/min		
6AGM1SN5-06CA	0 - 500 mL/min		
6AGM1SN5-07CA	0 - 1 L/min		
6AGM1SN5-08CA	0 - 2 L/min		
6AGM1SN5-09CA	0 - 5 L/min		
6AGM1SN5-10CA	0 - 10 L/min		
Stainless Steel with Display			
6AGM1SL5-01CA	0 - 10 mL/min	0-5 VDC	\$851.00
6AGM1SL5-02CA	0 - 20 mL/min		
6AGM1SL5-03CA	0 - 50 mL/min		
6AGM1SL5-04CA	0 - 100 mL/min		
6AGM1SL5-05CA	0 - 200 mL/min		
6AGM1SL5-06CA	0 - 500 mL/min		
6AGM1SL5-07CA	0 - 1 L/min		
6AGM1SL5-08CA	0 - 2 L/min		
6AGM1SL5-09CA	0 - 5 L/min		
6AGM1SL5-10CA	0 - 10 L/min		

TABLE 39-2 GM3 MEDIUM RANGE MASS FLOW METER

CARBON DIOXIDE			
MODEL NO.	FLOW RATE	OUTPUT	PRICE
Aluminum with No Display			
6AGM3AN5-29CA	0 - 15 L/min	0-5 VDC	\$575.00
6AGM3AN5-30CA	0 - 20 L/min		
6AGM3AN5-31CA	0 - 30 L/min		
6AGM3AN5-32CA	0 - 40 L/min		
6AGM3AN5-33CA	0 - 50 L/min		
Aluminum with Display			
6AGM3AL5-29CA	0 - 15 L/min	0-5 VDC	\$655.00
6AGM3AL5-30CA	0 - 20 L/min		
6AGM3AL5-31CA	0 - 30 L/min		
6AGM3AL5-32CA	0 - 40 L/min		
6AGM3AL5-33CA	0 - 50 L/min		
Stainless Steel with No Display			
6AGM3SN5-29CA	0 - 15 L/min	0-5 VDC	\$1000.00
6AGM3SN5-30CA	0 - 20 L/min		
6AGM3SN5-31CA	0 - 30 L/min		
6AGM3SN5-32CA	0 - 40 L/min		
6AGM3SN5-33CA	0 - 50 L/min		
Stainless Steel with Display			
6AGM3SL5-29CA	0 - 15 L/min	0-5 VDC	\$1081.00
6AGM3SL5-30CA	0 - 20 L/min		
6AGM3SL5-31CA	0 - 30 L/min		
6AGM3SL5-32CA	0 - 40 L/min		
6AGM3SL5-33CA	0 - 50 L/min		

TABLE 39-3 GM4 MEDIUM RANGE MASS FLOW METER

CARBON DIOXIDE			
MODEL NO.	FLOW RATE	OUTPUT	PRICE
Aluminum with No Display			
6AGM4AN5-40CA	0 - 60 L/min	0-5 VDC	\$771.00
6AGM4AN5-41CA	0 - 80 L/min		
6AGM4AN5-42CA	0 - 100 L/min		
Aluminum with Display			
6AGM4AL5-40CA	0 - 60 L/min	0-5 VDC	\$805.00
6AGM4AL5-41CA	0 - 80 L/min		
6AGM4AL5-42CA	0 - 100 L/min		
Stainless Steel with No Display			
6AGM4SN5-40CA	0 - 60 L/min	0-5 VDC	\$1196.00
6AGM4SN5-41CA	0 - 80 L/min		
6AGM4SN5-42CA	0 - 100 L/min		
Stainless Steel with Display			
6AGM4SL5-40CA	0 - 60 L/min	0-5 VDC	\$1236.00
6AGM4SL5-41CA	0 - 80 L/min		
6AGM4SL5-42CA	0 - 100 L/min		

TABLE 39-4 GM5 HIGH RANGE MASS FLOW METER

CARBON DIOXIDE			
MODEL NO.	FLOW RATE	OUTPUT	PRICE
Aluminum with No Display			
6AGM5AN5-50CA	0 - 200 L/min	0-5 VDC	\$895.00
Aluminum with Display			
6AGM5AL5-50CA	0 - 200 L/min	0-5 VDC	\$975.00
Stainless Steel with No Display			
6AGM5SN5-50CA	0 - 200 L/min	0-5 VDC	\$1420.00
Stainless Steel with Display			
6AGM5SL5-50CA	0 - 200 L/min	0-5 VDC	\$1500.00

TABLE 39-5 GM7 HIGH RANGE MASS FLOW METER

CARBON DIOXIDE			
MODEL NO.	FLOW RATE	OUTPUT	PRICE
Aluminum with No Display			
6AGM7AN5-70CA	0 - 1000 L/min	0-5 VDC	\$1090.00
Aluminum with Display			
6AGM7AL5-70CA	0 - 1000 L/min	0-5 VDC	\$1170.00
Stainless Steel with No Display			
6AGM7SN5-70CA	0 - 1000 L/min	0-5 VDC	\$1720.00
Stainless Steel with Display			
6AGM7SL5-70CA	0 - 1000 L/min	0-5 VDC	\$1800.00

TABLE 39-6 GM6 HIGH RANGE MASS FLOW METER

CARBON DIOXIDE			
MODEL NO.	FLOW RATE	OUTPUT	PRICE
Aluminum with No Display			
6AGM6AN5-60CA	0 - 500 L/min	0-5 VDC	\$960.00
Aluminum with Display			
6AGM6AL5-60CA	0 - 500 L/min	0-5 VDC	\$1040.00
Stainless Steel with No Display			
6AGM6SN5-60CA	0 - 500 L/min	0-5 VDC	\$1520.00
Stainless Steel with Display			
6AGM6SL5-60CA	0 - 200 L/min	0-5 VDC	\$1600.00

Optional Accessories see page 48

MASS FLOW CONTROLLERS

Thermal Mass Flow Controllers are designed to indicate and control set flow rates of gases.

The mass flow controller combines the characteristics, and accuracy of conventional mass flow devices into a unique compact design at low costs previously unattainable.

Each of these controllers incorporates an advanced straight tube sensor in conjunction with flow passage elements constructed of aluminum and brass for non-corrosive gases or 316 stainless steel for corrosive applications. Zero and span adjustments are accessible from the outside of transmitters.



*SPECIFICATIONS

ACCURACY:	ACCURACY %FS			OPTIONAL ENHANCED ACCURACY %FS			
	MODEL:	GC1, 3, 4	GC5, 6, 7		MODEL:	GC5, 6, 7	
FLOW RANGE:	0-100%	20-100%	0-20%	FLOW RANGE:	20-100%	0-20%	
ACCURACY:	±1.0%	±1.5%	±3%	ACCURACY:	±1%	±1.0%	REF DATA with ±1%

CALIBRATIONS: Performed at standard conditions [14.7 psia (101.4 kPa) and 70 °F (21.1°C)] unless otherwise requested.

REPEATABILITY: ±0.25% of full scale.

RESPONSE TIME: Generally 2 seconds to within ±2% of actual flow rate over 25 to 100% of full scale.

TEMPERATURE COEFFICIENT: 0.15% of full scale / °C.

PRESSURE COEFFICIENT: 0.01% of full scale / psi (0.07 bar).

PRESSURE DROP: See Table above.

OPTIMUM GAS PRESSURE: 25 psig (1.73 bars).

MAX. GAS PRESSURE: 1000 psig (70 bars) maximum GC1, 3, 4. 500 psig (34.5 bars) GC5, 6, 7.

TURN DOWN RATIO: 40:1.

MAX. DIFF. PRESSURE: 50 psi for GC1/3/5/6 and 7 (3.4 bars), 40 psi for 47 (2.7 bars).

GAS and AMBIENT TEMP: 32 °F to 122 °F (0 °C to 50 °C). 14 °F to 122 °F (-10 °C to 50 °C) - Dry gases only.

****MATERIALS FLUID CONTACT:**

a. Aluminum models GC Series: anodized aluminum, 316 stainless steel, brass and Viton® O-rings.

b. Stainless steel models GC1S, 3S, 4S, 5S, 6S and 7S: 316 stainless steel and Viton® O-rings.

Optional O-rings: Buna®, EPR and Kalrez®.

ATTITUDE SENSITIVITY: No greater than ±15 degree rotation from horizontal to vertical; standard calibration is in horizontal position.

OUTPUT SIGNALS: Linear 0-5 Vdc. (1000 ohms min. load impedance); 4-20 mA (0-500 ohms loop resistance) Max noise ±20mV.

COMMAND SIGNALS: Analog 0-5 Vdc or 4-20 mA for remote set point mode; NPN compatible purge /valve off.

CONNECTIONS: **GC1:** 1/4" compression fittings. *Optional:* 6mm, 3/8" and 1/8" compression fittings or 1/4" VCR®.

GC3: 1/4" compression fittings. *Optional:* 6mm and 3/8" compression fittings or 1/4" VCR®.

GC4: 3/8" compression fittings.

GC5: 3/8" compression fittings.

GC6: 1/2" compression fittings.

GC7: 3/4" FNPT fittings. *Optional:* 3/4" compression fittings.

LEAK INTEGRITY: 1 x 10⁻⁹ sml/sec of helium maximum to the outside environment.

TRANSDUCER INPUT POWER: GC1, 3 and 4: Universal +12 Vdc to 26 Vdc, 200 mA maximum.

GC5, 6 and 7: +12 Vdc, 800 mA; +24 Vdc, 650 mA optional.

CIRCUIT PROTECTION: Circuit boards have built-in polarity reversal protection. Resettable fuses provide power input protection.

DISPLAY: 3-1/2 digit LCD, 0.5" high characters.

CE COMPLIANT: EN 55011 class 1, class B; EN50082-1.

* The selection of materials of construction, is the responsibility of the customer. The company accepts no liability.

MASS FLOW CONTROLLERS

Aluminum and Stainless Mass Flow Controllers



DESIGN FEATURES

- ✓ Rigid metallic construction.
- ✓ Maximum pressure of 1000 psig (70 bars)
GC1, GC3, GC4. 500 psig (34.5 bars)
for GC5, GC6 and GC7.
- ✓ Leak integrity 1×10^{-9} smL/sec of helium.
- ✓ NIST traceable certification.
- ✓ Built-in tiltable LCD readout.
- ✓ Local or remote setpoint control.
- ✓ 0-5 Vdc and 4-20 mA signals.
- ✓ Circuit protection.
- ✓ Totalizer option.

MODEL	CONNECTION Compression Fitting (except model GC7)	DIMENSION (INCH)									
		LCD VERSION									NO LCD
		A	B	C/*C	D/*D	E/*E	F	G	H	I	
GC1	1/4" Tube O Diameter	5.60	1.00	1.00	4.27	6.29	0.69	2.68	3.56	4.50	
GC3	1/4" Tube O Diameter	5.98	1.37	1.25	5.19	7.21	0.69	2.68	3.94	4.88	
GC4	3/8" Tube O Diameter	5.98	1.37	1.25	5.19	7.33	0.69	2.68	3.94	4.88	
GC5	3/8" Tube O Diameter	6.60	2.00	1.75	10.2	12.3	0.99	4.68	6.88	5.50	
GC6	1/2" Tube O Diameter	7.56	3.00	3.00	10.0	12.4	-	-	7.55	6.46	
GC7	3/4" NPT Female	8.56	4.00	4.00	10.5	-	-	-	8.05	7.46	

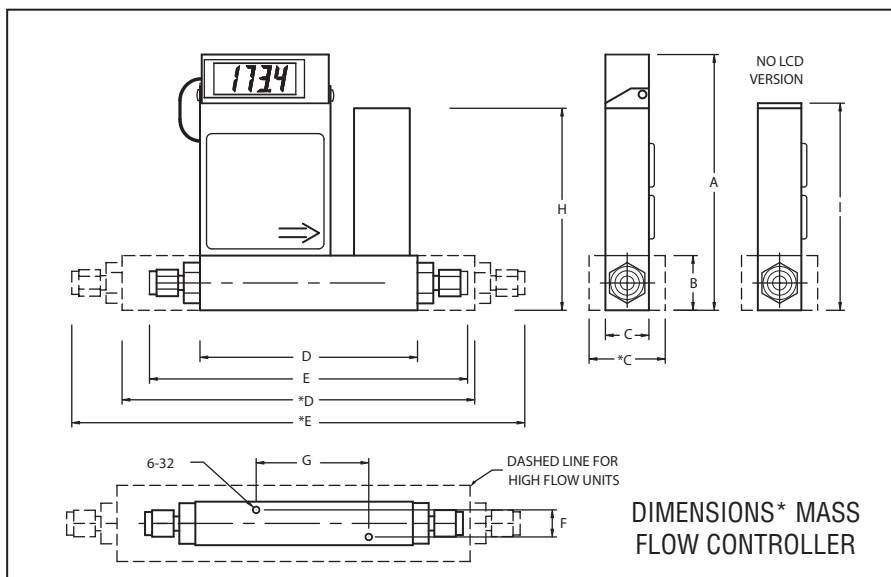

GENERAL DESCRIPTION

Compact, self contained mass flow controllers are designed to indicate and control flow rates of gases. The rugged design coupled with instrumentation grade accuracy provides versatile and economical means of flow control. Aluminum or stainless steel models with readout options of either engineering units (standard) or 0 to 100 percent displays are available.

The built-in electromagnetic valve allows the flow to be set to any desired flow rate within the range of the particular model. The valve is normally closed as a safety feature to ensure that gas flow is shut off in case of a power outage. Setpoints are controlled either locally or remotely.

The LCD readout built into the top of the transducer is tiltable over 90 degrees to provide optimal reading comfort. It is connected to the transducer by a standard modular plug, and is readily removable for remote reading installations. Transducers without LCD readout are offered for OEM applications.

The combined gas streams flow through a proportionating electromagnetic valve with an appropriately selected orifice. The closed loop control circuit continuously monitors the mass flow output and maintains it at the set flow rate.

Flow rates are unaffected by temperature and pressure variations within stated limitations.

Mass flow controllers are available with flow ranges from 10 sccm to 1000 sL/min N₂. Gases are connected by means of 1/4", 3/8", or optional 1/8" compression fittings and 3/4" FNPT fittings. Optional fittings are available. These controllers may be used as bench top units or mounted by means of screws in the base. Transducer power supply ports are fuse and polarity protected.

MODEL	FLOW RATE [std liters/min]	MAXIMUM PRESSURE DROP	
		[psid]	[bars]
GC1	up to 10	1.06	0.075
GC3	20	2.00	0.138
	30	3.5	0.241
	40	5.5	.379
GC4	50	8	.551
	100	18.9	1.302
GC5	300	10	690
GC6	500	12	827
GC7	1000	15	1034

GC Mass Flow Controller Models for Air 0-5 VDC

TABLE 42-1 GC1 LOW RANGE MASS FLOW CONTROLLER			
AIR			
MODEL NO.	FLOW RATE	OUTPUT	PRICE
Aluminum With No Display			
6AGC1AN5-01AB	0 - 10 mL/min	0-5 VDC	\$695.00
6AGC1AN5-02AB	0 - 20 mL/min		
6AGC1AN5-03AB	0 - 50 mL/min		
6AGC1AN5-04AB	0 - 100 mL/min		
6AGC1AN5-05AB	0 - 200 mL/min		
6AGC1AN5-06AB	0 - 500 mL/min		
6AGC1AN5-07AB	0 - 1 L/min		
6AGC1AN5-08AB	0 - 2 L/min		
6AGC1AN5-09AB	0 - 5 L/min		
6AGC1AN5-10AB	0 - 10 L/min		
Aluminum With Display			
6AGC1AL5-01AB	0 - 10 mL/min	0-5 VDC	\$775.00
6AGC1AL5-02AB	0 - 20 mL/min		
6AGC1AL5-03AB	0 - 50 mL/min		
6AGC1AL5-04AB	0 - 100 mL/min		
6AGC1AL5-05AB	0 - 200 mL/min		
6AGC1AL5-06AB	0 - 500 mL/min		
6AGC1AL5-07AB	0 - 1 L/min		
6AGC1AL5-08AB	0 - 2 L/min		
6AGC1AL5-09AB	0 - 5 L/min		
6AGC1AL5-10AB	0 - 10 L/min		
Stainless Steel with No Display			
6AGC1SN5-01AB	0 - 10 mL/min	0-5 VDC	\$860.00
6AGC1SN5-02AB	0 - 20 mL/min		
6AGC1SN5-03AB	0 - 50 mL/min		
6AGC1SN5-04AB	0 - 100 mL/min		
6AGC1SN5-05AB	0 - 200 mL/min		
6AGC1SN5-06AB	0 - 500 mL/min		
6AGC1SN5-07AB	0 - 1 L/min		
6AGC1SN5-08AB	0 - 2 L/min		
6AGC1SN5-09AB	0 - 5 L/min		
6AGC1SN5-10AB	0 - 10 L/min		
Stainless Steel with Display			
6AGC1SL5-01AB	0 - 10 mL/min	0-5 VDC	\$940.00
6AGC1SL5-02AB	0 - 20 mL/min		
6AGC1SL5-03AB	0 - 50 mL/min		
6AGC1SL5-04AB	0 - 100 mL/min		
6AGC1SL5-05AB	0 - 200 mL/min		
6AGC1SL5-06AB	0 - 500 mL/min		
6AGC1SL5-07AB	0 - 1 L/min		
6AGC1SL5-08AB	0 - 2 L/min		
6AGC1SL5-09AB	0 - 5 L/min		
6AGC1SL5-10AB	0 - 10 L/min		

TABLE 42-2 GC3 MEDIUM RANGE MASS FLOW CONTROLLER			
AIR			
MODEL NO.	FLOW RATE	OUTPUT	PRICE
Aluminum with No Display			
6AGC3AN5-29AB	0 - 15 L/min	0-5 VDC	\$860.00
6AGC3AN5-30AB	0 - 20 L/min		
6AGC3AN5-31AB	0 - 30 L/min		
6AGC3AN5-32AB	0 - 40 L/min		
6AGC3AN5-33AB	0 - 50 L/min		
Aluminum with Display			
6AGC3AL5-29AB	0 - 15 L/min	0-5 VDC	\$940.00
6AGC3AL5-30AB	0 - 20 L/min		
6AGC3AL5-31AB	0 - 30 L/min		
6AGC3AL5-32AB	0 - 40 L/min		
6AGC3AL5-33AB	0 - 50 L/min		
Stainless Steel with No Display			
6AGC3SN5-29AB	0 - 15 L/min	0-5 VDC	\$1060.00
6AGC3SN5-30AB	0 - 20 L/min		
6AGC3SN5-31AB	0 - 30 L/min		
6AGC3SN5-32AB	0 - 40 L/min		
6AGC3SN5-33AB	0 - 50 L/min		
Stainless Steel with Display			
6AGC3SL5-29AB	0 - 15 L/min	0-5 VDC	\$1140.00
6AGC3SL5-30AB	0 - 20 L/min		
6AGC3SL5-31AB	0 - 30 L/min		
6AGC3SL5-32AB	0 - 40 L/min		
6AGC3SL5-33AB	0 - 50 L/min		

TABLE 42-3 GC4 MEDIUM RANGE MASS FLOW CONTROLLER			
AIR			
MODEL NO.	FLOW RATE	OUTPUT	PRICE
Aluminum with No Display			
6AGC4AN5-40AB	0 - 60 L/min	0-5 VDC	\$1010.00
6AGC4AN5-41AB	0 - 80 L/min		
6AGC4AN5-42AB	0 - 100 L/min		
Aluminum with Display			
6AGC4AL5-40AB	0 - 60 L/min	0-5 VDC	\$1090.00
6AGC4AL5-41AB	0 - 80 L/min		
6AGC4AL5-42AB	0 - 100 L/min		
Stainless Steel with No Display			
6AGC4SN5-40AB	0 - 60 L/min	0-5 VDC	\$1210.00
6AGC4SN5-41AB	0 - 80 L/min		
6AGC4SN5-42AB	0 - 100 L/min		
Stainless Steel with Display			
6AGC4SL5-40AB	0 - 60 L/min	0-5 VDC	\$1290.00
6AGC4SL5-41AB	0 - 80 L/min		
6AGC4SL5-42AB	0 - 100 L/min		

TABLE 42-4 GC5 HIGH RANGE MASS FLOW CONTROLLER			
AIR			
MODEL NO.	FLOW RATE	OUTPUT	PRICE
Aluminum with No Display			
6AGC5AN5-50AB	0 - 200 L/min	0-5 VDC	\$1155.00
Aluminum with Display			
6AGC5AL5-50AB	0 - 200 L/min	0-5 VDC	\$1235.00
Stainless Steel with No Display			
6AGC5SN5-50AB	0 - 200 L/min	0-5 VDC	\$1820.00
Stainless Steel with Display			
6AGC5SL5-50AB	0 - 200 L/min	0-5 VDC	\$1900.00

TABLE 42-5 GC6 HIGH RANGE MASS FLOW CONTROLLER			
AIR			
MODEL NO.	FLOW RATE	OUTPUT	PRICE
Aluminum with No Display			
6AGC6AN5-60AB	0 - 500 L/min	0-5 VDC	\$1350.00
Aluminum with Display			
6AGC6AL5-60AB	0 - 500 L/min	0-5 VDC	\$1430.00
Stainless Steel with No Display			
6AGC6SN5-60AB	0 - 500 L/min	0-5 VDC	\$2120.00
Stainless Steel with Display			
6AGC6SL5-60AB	0 - 500 L/min	0-5 VDC	\$2200.00

TABLE 42-6 GC7 HIGH RANGE MASS FLOW CONTROLLER			
AIR			
MODEL NO.	FLOW RATE	OUTPUT	PRICE
Aluminum with No Display			
6AGC7AN5-70AB	0 - 1000 L/min	0-5 VDC	\$1740.00
Aluminum with Display			
6AGC7AL5-70AB	0 - 1000 L/min	0-5 VDC	\$1820.00
Stainless Steel with No Display			
6AGC7SN5-70AB	0 - 1000 L/min	0-5 VDC	\$2720.00
Stainless Steel with Display			
6AGC7SL5-70AB	0 - 1000 L/min	0-5 VDC	\$2800.00

Optional Accessories see page 48

MASS FLOW CONTROLLERS

GC Mass Flow Controller Models for Air 0-5 VDC

TABLE 43-1 GC1 LOW RANGE MASS FLOW CONTROLLER			
AIR			
MODEL NO.	FLOW RATE	OUTPUT	PRICE
Aluminum With No Display			
6AGC1AN4-01AB	0 - 10 mL/min	4-20 mA	\$695.00
6AGC1AN4-02AB	0 - 20 mL/min		
6AGC1AN4-03AB	0 - 50 mL/min		
6AGC1AN4-04AB	0 - 100 mL/min		
6AGC1AN4-05AB	0 - 200 mL/min		
6AGC1AN4-06AB	0 - 500 mL/min		
6AGC1AN4-07AB	0 - 1 L/min		
6AGC1AN4-08AB	0 - 2 L/min		
6AGC1AN4-09AB	0 - 5 L/min		
6AGC1AN4-10AB	0 - 10 L/min		
Aluminum With Display			
6AGC1AL4-01AB	0 - 10 mL/min	4-20 mA	\$775.00
6AGC1AL4-02AB	0 - 20 mL/min		
6AGC1AL4-03AB	0 - 50 mL/min		
6AGC1AL4-04AB	0 - 100 mL/min		
6AGC1AL4-05AB	0 - 200 mL/min		
6AGC1AL4-06AB	0 - 500 mL/min		
6AGC1AL4-07AB	0 - 1 L/min		
6AGC1AL4-08AB	0 - 2 L/min		
6AGC1AL4-09AB	0 - 5 L/min		
6AGC1AL4-10AB	0 - 10 L/min		
Stainless Steel with No Display			
6AGC1SN5-01AB	0 - 10 mL/min	4-20 mA	\$860.00
6AGC1SN5-02AB	0 - 20 mL/min		
6AGC1SN5-03AB	0 - 50 mL/min		
6AGC1SN5-04AB	0 - 100 mL/min		
6AGC1SN5-05AB	0 - 200 mL/min		
6AGC1SN5-06AB	0 - 500 mL/min		
6AGC1SN5-07AB	0 - 1 L/min		
6AGC1SN5-08AB	0 - 2 L/min		
6AGC1SN5-09AB	0 - 5 L/min		
6AGC1SN5-10AB	0 - 10 L/min		
Stainless Steel with Display			
6AGC1SL5-01AB	0 - 10 mL/min	4-20 mA	\$940.00
6AGC1SL5-02AB	0 - 20 mL/min		
6AGC1SL5-03AB	0 - 50 mL/min		
6AGC1SL5-04AB	0 - 100 mL/min		
6AGC1SL5-05AB	0 - 200 mL/min		
6AGC1SL5-06AB	0 - 500 mL/min		
6AGC1SL5-07AB	0 - 1 L/min		
6AGC1SL5-08AB	0 - 2 L/min		
6AGC1SL5-09AB	0 - 5 L/min		
6AGC1SL5-10AB	0 - 10 L/min		

TABLE 43-2 GC3 MEDIUM RANGE MASS FLOW CONTROLLER			
AIR			
MODEL NO.	FLOW RATE	OUTPUT	PRICE
Aluminum with No Display			
6AGC3AN4-29AB	0 - 15 L/min	4-20 mA	\$860.00
6AGC3AN4-30AB	0 - 20 L/min		
6AGC3AN4-31AB	0 - 30 L/min		
6AGC3AN4-32AB	0 - 40 L/min		
6AGC3AN4-33AB	0 - 50 L/min		
Aluminum with Display			
6AGC3AL4-29AB	0 - 15 L/min	4-20 mA	\$940.00
6AGC3AL4-30AB	0 - 20 L/min		
6AGC3AL4-31AB	0 - 30 L/min		
6AGC3AL4-32AB	0 - 40 L/min		
6AGC3AL4-33AB	0 - 50 L/min		
Stainless Steel with No Display			
6AGC3SN5-29AB	0 - 15 L/min	4-20 mA	\$1060.00
6AGC3SN5-30AB	0 - 20 L/min		
6AGC3SN5-31AB	0 - 30 L/min		
6AGC3SN5-32AB	0 - 40 L/min		
6AGC3SN5-33AB	0 - 50 L/min		
Stainless Steel with Display			
6AGC3SL5-29AB	0 - 15 L/min	4-20 mA	\$1140.00
6AGC3SL5-30AB	0 - 20 L/min		
6AGC3SL5-31AB	0 - 30 L/min		
6AGC3SL5-32AB	0 - 40 L/min		
6AGC3SL5-33AB	0 - 50 L/min		

TABLE 43-3 GC4 MEDIUM RANGE MASS FLOW CONTROLLER			
AIR			
MODEL NO.	FLOW RATE	OUTPUT	PRICE
Aluminum with No Display			
6AGC4AN4-40AB	0 - 60 L/min	4-20 mA	\$1010.00
6AGC4AN4-41AB	0 - 80 L/min		
6AGC4AN4-42AB	0 - 100 L/min		
Aluminum with Display			
6AGC4AL4-40AB	0 - 60 L/min	4-20 mA	\$1090.00
6AGC4AL4-41AB	0 - 80 L/min		
6AGC4AL4-42AB	0 - 100 L/min		
Stainless Steel with No Display			
6AGC4SN5-40AB	0 - 60 L/min	4-20 mA	\$1210.00
6AGC4SN5-41AB	0 - 80 L/min		
6AGC4SN5-42AB	0 - 100 L/min		
Stainless Steel with Display			
6AGC4SL5-40AB	0 - 60 L/min	4-20 mA	\$1290.00
6AGC4SL5-41AB	0 - 80 L/min		
6AGC4SL5-42AB	0 - 100 L/min		

TABLE 43-4 GC5 HIGH RANGE MASS FLOW CONTROLLER			
AIR			
MODEL NO.	FLOW RATE	OUTPUT	PRICE
Aluminum with No Display			
6AGC5AN4-50AB	0 - 200 L/min	4-20 mA	\$1155.00
Aluminum with Display			
6AGC5AL4-50AB	0 - 200 L/min	4-20 mA	\$1235.00
Stainless Steel with No Display			
6AGC5SN5-50AB	0 - 200 L/min	4-20 mA	\$1820.00
Stainless Steel with Display			
6AGC5SL5-50AB	0 - 200 L/min	4-20 mA	\$1900.00

TABLE 43-5 GC6 HIGH RANGE MASS FLOW CONTROLLER			
AIR			
MODEL NO.	FLOW RATE	OUTPUT	PRICE
Aluminum with No Display			
6AGC6AN4-60AB	0 - 500 L/min	4-20 mA	\$1350.00
Aluminum with Display			
6AGC6AL4-60AB	0 - 500 L/min	4-20 mA	\$1430.00
Stainless Steel with No Display			
6AGC6SN5-60AB	0 - 500 L/min	4-20 mA	\$2120.00
Stainless Steel with Display			
6AGC6SL5-60AB	0 - 500 L/min	4-20 mA	\$2200.00

TABLE 43-6 GC7 HIGH RANGE MASS FLOW CONTROLLER			
AIR			
MODEL NO.	FLOW RATE	OUTPUT	PRICE
Aluminum with No Display			
6AGC7AN4-70AB	0 - 1000 L/min	4-20 mA	\$1740.00
Aluminum with Display			
6AGC7AL4-70AB	0 - 1000 L/min	4-20 mA	\$1820.00
Stainless Steel with No Display			
6AGC7SN5-70AB	0 - 1000 L/min	4-20 mA	\$2720.00
Stainless Steel with Display			
6AGC7SL5-70AB	0 - 1000 L/min	4-20 mA	\$2800.00

Optional Accessories see page 48

GC Mass Flow Controllers Models for Nitrogen 4-20 mA

TABLE 44-1 GC1 LOW RANGE MASS FLOW CONTROLLER			
NITROGEN			
MODEL NO.	FLOW RATE	OUTPUT	PRICE
Aluminum With No Display			
6AGC1AN4-01NC	0 - 10 mL/min	4-20mA	\$695.00
6AGC1AN4-02NC	0 - 20 mL/min		
6AGC1AN4-03NC	0 - 50 mL/min		
6AGC1AN4-04NC	0 - 100 mL/min		
6AGC1AN4-05NC	0 - 200 mL/min		
6AGC1AN4-06NC	0 - 500 mL/min		
6AGC1AN4-07NC	0 - 1 L/min		
6AGC1AN4-08NC	0 - 2 L/min		
6AGC1AN4-09NC	0 - 5 L/min		
6AGC1AN4-10NC	0 - 10 L/min		
Aluminum With Display			
6AGC1AL4-01NC	0 - 10 mL/min	4-20mA	\$775.00
6AGC1AL4-02NC	0 - 20 mL/min		
6AGC1AL4-03NC	0 - 50 mL/min		
6AGC1AL4-04NC	0 - 100 mL/min		
6AGC1AL4-05NC	0 - 200 mL/min		
6AGC1AL4-06NC	0 - 500 mL/min		
6AGC1AL4-07NC	0 - 1 L/min		
6AGC1AL4-08NC	0 - 2 L/min		
6AGC1AL4-09NC	0 - 5 L/min		
6AGC1AL4-10NC	0 - 10 L/min		
Stainless Steel with No Display			
6AGC1SN4-01NC	0 - 10 mL/min	4-20mA	\$860.00
6AGC1SN4-02NC	0 - 20 mL/min		
6AGC1SN4-03NC	0 - 50 mL/min		
6AGC1SN4-04NC	0 - 100 mL/min		
6AGC1SN4-05NC	0 - 200 mL/min		
6AGC1SN4-06NC	0 - 500 mL/min		
6AGC1SN4-07NC	0 - 1 L/min		
6AGC1SN4-08NC	0 - 2 L/min		
6AGC1SN4-09NC	0 - 5 L/min		
6AGC1SN4-10NC	0 - 10 L/min		
Stainless Steel with Display			
6AGC1SL4-01NC	0 - 10 mL/min	4-20mA	\$940.00
6AGC1SL4-02NC	0 - 20 mL/min		
6AGC1SL4-03NC	0 - 50 mL/min		
6AGC1SL4-04NC	0 - 100 mL/min		
6AGC1SL4-05NC	0 - 200 mL/min		
6AGC1SL4-06NC	0 - 500 mL/min		
6AGC1SL4-07NC	0 - 1 L/min		
6AGC1SL4-08NC	0 - 2 L/min		
6AGC1SL4-09NC	0 - 5 L/min		
6AGC1SL4-10NC	0 - 10 L/min		

TABLE 44-2 GC3 MEDIUM RANGE MASS FLOW CONTROLLER			
NITROGEN			
MODEL NO.	FLOW RATE	OUTPUT	PRICE
Aluminum with No Display			
6AGC3AN4-29NC	0 - 15 L/min	4-20mA	\$860.00
6AGC3AN4-30NC	0 - 20 L/min		
6AGC3AN4-31NC	0 - 30 L/min		
6AGC3AN4-32NC	0 - 40 L/min		
6AGC3AN4-33NC	0 - 50 L/min		
Aluminum with Display			
6AGC3AL4-29NC	0 - 15 L/min	4-20mA	\$940.00
6AGC3AL4-30NC	0 - 20 L/min		
6AGC3AL4-31NC	0 - 30 L/min		
6AGC3AL4-32NC	0 - 40 L/min		
6AGC3AL4-33NC	0 - 50 L/min		
Stainless Steel with No Display			
6AGC3SN4-29NC	0 - 15 L/min	4-20mA	\$1060.00
6AGC3SN4-30NC	0 - 20 L/min		
6AGC3SN4-31NC	0 - 30 L/min		
6AGC3SN4-32NC	0 - 40 L/min		
6AGC3SN4-33NC	0 - 50 L/min		
Stainless Steel with Display			
6AGC3SL4-29NC	0 - 15 L/min	4-20mA	\$1140.00
6AGC3SL4-30NC	0 - 20 L/min		
6AGC3SL4-31NC	0 - 30 L/min		
6AGC3SL4-32NC	0 - 40 L/min		
6AGC3SL4-33NC	0 - 50 L/min		

TABLE 44-3 GC4 MEDIUM RANGE MASS FLOW CONTROLLER			
NITROGEN			
MODEL NO.	FLOW RATE	OUTPUT	PRICE
Aluminum with No Display			
6AGC4AN4-40NC	0 - 60 L/min	4-20mA	\$1010.00
6AGC4AN4-41NC	0 - 80 L/min		
6AGC4AN4-42NC	0 - 100 L/min		
Aluminum with Display			
6AGC4AL4-40NC	0 - 60 L/min	4-20mA	\$1090.00
6AGC4AL4-41NC	0 - 80 L/min		
6AGC4AL4-42NC	0 - 100 L/min		
Stainless Steel with No Display			
6AGC4SN4-40NC	0 - 60 L/min	4-20mA	\$1210.00
6AGC4SN4-41NC	0 - 80 L/min		
6AGC4SN4-42NC	0 - 100 L/min		
Stainless Steel with Display			
6AGC4SL4-40NC	0 - 60 L/min	4-20mA	\$1290.00
6AGC4SL4-41NC	0 - 80 L/min		
6AGC4SL4-42NC	0 - 100 L/min		

TABLE 44-4 GC5 HIGH RANGE MASS FLOW CONTROLLER			
NITROGEN			
MODEL NO.	FLOW RATE	OUTPUT	PRICE
Aluminum with No Display			
6AGC5AN4-50NC	0 - 200 L/min	4-20mA	\$1155.00
Aluminum with Display			
6AGC5AL4-50NC	0 - 200 L/min	4-20mA	\$1235.00
Stainless Steel with No Display			
6AGC5SN4-50NC	0 - 200 L/min	4-20mA	\$1820.00
Stainless Steel with Display			
6AGC5SL4-50NC	0 - 200 L/min	4-20mA	\$1900.00

TABLE 44-5 GC6 HIGH RANGE MASS FLOW CONTROLLER			
NITROGEN			
MODEL NO.	FLOW RATE	OUTPUT	PRICE
Aluminum with No Display			
6AGC6AN4-60NC	0 - 500 L/min	4-20mA	\$1350.00
Aluminum with Display			
6AGC6AL4-60NC	0 - 500 L/min	4-20mA	\$1430.00
Stainless Steel with No Display			
6AGC6SN4-60NC	0 - 500 L/min	4-20mA	\$2120.00
Stainless Steel with Display			
6AGC6SL4-60NC	0 - 500 L/min	4-20mA	\$2200.00

TABLE 44-6 GC7 HIGH RANGE MASS FLOW CONTROLLER			
NITROGEN			
MODEL NO.	FLOW RATE	OUTPUT	PRICE
Aluminum with No Display			
6AGC7AN4-70NC	0 - 1000 L/min	4-20mA	\$1740.00
Aluminum with Display			
6AGC7AL4-70NC	0 - 1000 L/min	4-20mA	\$1820.00
Stainless Steel with No Display			
6AGC7SN4-70NC	0 - 1000 L/min	4-20mA	\$2120.00
Stainless Steel with Display			
6AGC7SL4-70NC	0 - 1000 L/min	4-20mA	\$2800.00

MASS FLOW CONTROLLERS

GC Mass Flow Controllers Models for Nitrogen 4-20 mA

TABLE 45-1 GC1 LOW RANGE MASS FLOW CONTROLLER			
NITROGEN			
MODEL NO.	FLOW RATE	OUTPUT	PRICE
Aluminum With No Display			
6AGC1AN5-01NC	0 - 10 mL/min	4-20mA	\$695.00
6AGC1AN5-02NC	0 - 20 mL/min		
6AGC1AN5-03NC	0 - 50 mL/min		
6AGC1AN5-04NC	0 - 100 mL/min		
6AGC1AN5-05NC	0 - 200 mL/min		
6AGC1AN5-06NC	0 - 500 mL/min		
6AGC1AN5-07NC	0 - 1 L/min		
6AGC1AN5-08NC	0 - 2 L/min		
6AGC1AN5-09NC	0 - 5 L/min		
6AGC1AN5-10NC	0 - 10 L/min		
Aluminum With Display			
6AGC1AL5-01NC	0 - 10 mL/min	4-20mA	\$775.00
6AGC1AL5-02NC	0 - 20 mL/min		
6AGC1AL5-03NC	0 - 50 mL/min		
6AGC1AL5-04NC	0 - 100 mL/min		
6AGC1AL5-05NC	0 - 200 mL/min		
6AGC1AL5-06NC	0 - 500 mL/min		
6AGC1AL5-07NC	0 - 1 L/min		
6AGC1AL5-08NC	0 - 2 L/min		
6AGC1AL5-09NC	0 - 5 L/min		
6AGC1AL5-10NC	0 - 10 L/min		
Stainless Steel with No Display			
6AGC1SN4-01NC	0 - 10 mL/min	4-20mA	\$860.00
6AGC1SN4-02NC	0 - 20 mL/min		
6AGC1SN4-03NC	0 - 50 mL/min		
6AGC1SN4-04NC	0 - 100 mL/min		
6AGC1SN4-05NC	0 - 200 mL/min		
6AGC1SN4-06NC	0 - 500 mL/min		
6AGC1SN4-07NC	0 - 1 L/min		
6AGC1SN4-08NC	0 - 2 L/min		
6AGC1SN4-09NC	0 - 5 L/min		
6AGC1SN4-10NC	0 - 10 L/min		
Stainless Steel with Display			
6AGC1SL4-01NC	0 - 10 mL/min	4-20mA	\$940.00
6AGC1SL4-02NC	0 - 20 mL/min		
6AGC1SL4-03NC	0 - 50 mL/min		
6AGC1SL4-04NC	0 - 100 mL/min		
6AGC1SL4-05NC	0 - 200 mL/min		
6AGC1SL4-06NC	0 - 500 mL/min		
6AGC1SL4-07NC	0 - 1 L/min		
6AGC1SL4-08NC	0 - 2 L/min		
6AGC1SL4-09NC	0 - 5 L/min		
6AGC1SL4-10NC	0 - 10 L/min		

TABLE 45-2 GC3 MEDIUM RANGE MASS FLOW CONTROLLER			
NITROGEN			
MODEL NO.	FLOW RATE	OUTPUT	PRICE
Aluminum with No Display			
6AGC3AN5-29NC	0 - 15 L/min	4-20mA	\$860.00
6AGC3AN5-30NC	0 - 20 L/min		
6AGC3AN5-31NC	0 - 30 L/min		
6AGC3AN5-32NC	0 - 40 L/min		
6AGC3AN5-33NC	0 - 50 L/min		
Aluminum with Display			
6AGC3AL5-29NC	0 - 15 L/min	4-20mA	\$940.00
6AGC3AL5-30NC	0 - 20 L/min		
6AGC3AL5-31NC	0 - 30 L/min		
6AGC3AL5-32NC	0 - 40 L/min		
6AGC3AL5-33NC	0 - 50 L/min		
Stainless Steel with No Display			
6AGC3SN4-29NC	0 - 15 L/min	4-20mA	\$1060.00
6AGC3SN4-30NC	0 - 20 L/min		
6AGC3SN4-31NC	0 - 30 L/min		
6AGC3SN4-32NC	0 - 40 L/min		
6AGC3SN4-33NC	0 - 50 L/min		
Stainless Steel with Display			
6AGC3SL4-29NC	0 - 15 L/min	4-20mA	\$1140.00
6AGC3SL4-30NC	0 - 20 L/min		
6AGC3SL4-31NC	0 - 30 L/min		
6AGC3SL4-32NC	0 - 40 L/min		
6AGC3SL4-33NC	0 - 50 L/min		

TABLE 45-3 GC4 MEDIUM RANGE MASS FLOW CONTROLLER			
NITROGEN			
MODEL NO.	FLOW RATE	OUTPUT	PRICE
Aluminum with No Display			
6AGC4AN5-40NC	0 - 60 L/min	4-20mA	\$1010.00
6AGC4AN5-41NC	0 - 80 L/min		
6AGC4AN5-42NC	0 - 100 L/min		
Aluminum with Display			
6AGC4AL5-40NC	0 - 60 L/min	4-20mA	\$1090.00
6AGC4AL5-41NC	0 - 80 L/min		
6AGC4AL5-42NC	0 - 100 L/min		
Stainless Steel with No Display			
6AGC4SN4-40NC	0 - 60 L/min	4-20mA	\$1210.00
6AGC4SN4-41NC	0 - 80 L/min		
6AGC4SN4-42NC	0 - 100 L/min		
Stainless Steel with Display			
6AGC4SL4-40NC	0 - 60 L/min	4-20mA	\$1290.00
6AGC4SL4-41NC	0 - 80 L/min		
6AGC4SL4-42NC	0 - 100 L/min		

TABLE 45-4 GC5 HIGH RANGE MASS FLOW CONTROLLER			
NITROGEN			
MODEL NO.	FLOW RATE	OUTPUT	PRICE
Aluminum with No Display			
6AGC5AN5-50NC	0 - 200 L/min	4-20mA	\$1155.00
Aluminum with Display			
6AGC5AL5-50NC	0 - 200 L/min	4-20mA	\$1235.00
Stainless Steel with No Display			
6AGC5SN4-50NC	0 - 200 L/min	4-20mA	\$1820.00
Stainless Steel with Display			
6AGC5SL4-50NC	0 - 200 L/min	4-20mA	\$1900.00

TABLE 45-5 GC6 HIGH RANGE MASS FLOW CONTROLLER			
NITROGEN			
MODEL NO.	FLOW RATE	OUTPUT	PRICE
Aluminum with No Display			
6AGC6AN5-60NC	0 - 500 L/min	4-20mA	\$1350.00
Aluminum with Display			
6AGC6AL5-60NC	0 - 500 L/min	4-20mA	\$1430.00
Stainless Steel with No Display			
6AGC6SN4-60NC	0 - 500 L/min	4-20mA	\$2120.00
Stainless Steel with Display			
6AGC6SL4-60NC	0 - 500 L/min	4-20mA	\$2200.00

TABLE 45-6 GC7 HIGH RANGE MASS FLOW CONTROLLER			
NITROGEN			
MODEL NO.	FLOW RATE	OUTPUT	PRICE
Aluminum with No Display			
6AGC7AN5-70NC	0 - 1000 L/min	4-20mA	\$1740.00
Aluminum with Display			
6AGC7AL5-70NC	0 - 1000 L/min	4-20mA	\$1820.00
Stainless Steel with No Display			
6AGC7SN4-70NC	0 - 1000 L/min	4-20mA	\$2120.00
Stainless Steel with Display			
6AGC7SL4-70NC	0 - 1000 L/min	4-20mA	\$2800.00

GC Mass Flow Controller Models for Oxygen

**TABLE 46-1 GC1 LOW RANGE
MASS FLOW CONTROLLER**

OXYGEN			
MODEL NO.	FLOW RATE	INPUT/OUTPUT	PRICE
Aluminum With No Display			
6AGC1AN5I-01	0 - 10 mL/min	0-5 VDC/ 0-5 VDC	\$695.00
6AGC1AN5I-02	0 - 20 mL/min		
6AGC1AN5I-03	0 - 50 mL/min		
6AGC1AN5I-04	0 - 100 mL/min		
6AGC1AN5I-05	0 - 200 mL/min		
6AGC1AN5I-06	0 - 500 mL/min		
6AGC1AN5I-07	0 - 1 L/min		
6AGC1AN5I-08	0 - 2 L/min		
6AGC1AN5I-09	0 - 5 L/min		
6AGC1AN5I-10	0 - 10 L/min		
Aluminum With Display			
6AGC1AL5I-01	0 - 10 mL/min	0-5 VDC/ 0-5 VDC	\$775.00
6AGC1AL5I-02	0 - 20 mL/min		
6AGC1AL5I-03	0 - 50 mL/min		
6AGC1AL5I-04	0 - 100 mL/min		
6AGC1AL5I-05	0 - 200 mL/min		
6AGC1AL5I-06	0 - 500 mL/min		
6AGC1AL5I-07	0 - 1 L/min		
6AGC1AL5I-08	0 - 2 L/min		
6AGC1AL5I-09	0 - 5 L/min		
6AGC1AL5I-10	0 - 10 L/min		
Stainless Steel with No Display			
6AGC1SN5I-01	0 - 10 mL/min	0-5 VDC/ 0-5 VDC	\$860.00
6AGC1SN5I-02	0 - 20 mL/min		
6AGC1SN5I-03	0 - 50 mL/min		
6AGC1SN5I-04	0 - 100 mL/min		
6AGC1SN5I-05	0 - 200 mL/min		
6AGC1SN5I-06	0 - 500 mL/min		
6AGC1SN5I-07	0 - 1 L/min		
6AGC1SN5I-08	0 - 2 L/min		
6AGC1SN5I-09	0 - 5 L/min		
6AGC1SN5I-10	0 - 10 L/min		
Stainless Steel with Display			
6AGC1SL5I-01	0 - 10 mL/min	0-5 VDC/ 0-5 VDC	\$940.00
6AGC1SL5I-02	0 - 20 mL/min		
6AGC1SL5I-03	0 - 50 mL/min		
6AGC1SL5I-04	0 - 100 mL/min		
6AGC1SL5I-05	0 - 200 mL/min		
6AGC1SL5I-06	0 - 500 mL/min		
6AGC1SL5I-07	0 - 1 L/min		
6AGC1SL5I-08	0 - 2 L/min		
6AGC1SL5I-09	0 - 5 L/min		
6AGC1SL5I-10	0 - 10 L/min		

**TABLE 46-2 GC3 MEDIUM RANGE
MASS FLOW CONTROLLER**

OXYGEN			
MODEL NO.	FLOW RATE	INPUT/OUTPUT	PRICE
Aluminum with No Display			
6AGC3AN5I-29	0 - 15 L/min	0-5 VDC/ 0-5 VDC	\$860.00
6AGC3AN5I-30	0 - 20 L/min		
6AGC3AN5I-31	0 - 30 L/min		
6AGC3AN5I-32	0 - 40 L/min		
6AGC3AN5I-33	0 - 50 L/min		
Aluminum with Display			
6AGC3AL5I-29	0 - 15 L/min	0-5 VDC/ 0-5 VDC	\$940.00
6AGC3AL5I-30	0 - 20 L/min		
6AGC3AL5I-31	0 - 30 L/min		
6AGC3AL5I-32	0 - 40 L/min		
6AGC3AL5I-33	0 - 50 L/min		
Stainless Steel with No Display			
6AGC3SN5I-29	0 - 15 L/min	0-5 VDC/ 0-5 VDC	\$1060.00
6AGC3SN5I-30	0 - 20 L/min		
6AGC3SN5I-31	0 - 30 L/min		
6AGC3SN5I-32	0 - 40 L/min		
6AGC3SN5I-33	0 - 50 L/min		
Stainless Steel with Display			
6AGC3SL5I-29	0 - 15 L/min	0-5 VDC/ 0-5 VDC	\$1140.00
6AGC3SL5I-30	0 - 20 L/min		
6AGC3SL5I-31	0 - 30 L/min		
6AGC3SL5I-32	0 - 40 L/min		
6AGC3SL5I-33	0 - 50 L/min		

**TABLE 46-3 GC4 MEDIUM RANGE
MASS FLOW CONTROLLER**

OXYGEN			
MODEL NO.	FLOW RATE	INPUT/OUTPUT	PRICE
Aluminum with No Display			
6AGC4AN5I-40	0 - 60 L/min	0-5 VDC/ 0-5 VDC	\$1010.00
6AGC4AN5I-41	0 - 80 L/min		
6AGC4AN5I-42	0 - 100 L/min		
Aluminum with Display			
6AGC4AL5I-40	0 - 60 L/min	0-5 VDC/ 0-5 VDC	\$1090.00
6AGC4AL5I-41	0 - 80 L/min		
6AGC4AL5I-42	0 - 100 L/min		
Stainless Steel with No Display			
6AGC4SN5I-40	0 - 60 L/min	0-5 VDC/ 0-5 VDC	\$1210.00
6AGC4SN5I-41	0 - 80 L/min		
6AGC4SN5I-42	0 - 100 L/min		
Stainless Steel with Display			
6AGC4SL5I-40	0 - 60 L/min	0-5 VDC/ 0-5 VDC	\$1290.00
6AGC4SL5I-41	0 - 80 L/min		
6AGC4SL5I-42	0 - 100 L/min		

**TABLE 46-4 GC5 HIGH RANGE
MASS FLOW CONTROLLER**

OXYGEN			
MODEL NO.	FLOW RATE	INPUT/OUTPUT	PRICE
Aluminum with No Display			
6AGC5AN5I-50	0 - 200 L/min	0-5 VDC/ 0-5 VDC	\$1155.00
Aluminum with Display			
6AGC5AL5I-50	0 - 200 L/min	0-5 VDC/ 0-5 VDC	\$1235.00
Stainless Steel with No Display			
6AGC5SN5I-50	0 - 200 L/min	0-5 VDC/ 0-5 VDC	\$1820.00
Stainless Steel with Display			
6AGC5SL5I-50	0 - 200 L/min	0-5 VDC/ 0-5 VDC	\$1900.00

**TABLE 46-5 GC6 HIGH RANGE
MASS FLOW CONTROLLER**

OXYGEN			
MODEL NO.	FLOW RATE	INPUT/OUTPUT	PRICE
Aluminum with No Display			
6AGC6AN5I-60	0 - 500 L/min	0-5 VDC/ 0-5 VDC	\$1350.00
Aluminum with Display			
6AGC6AL5I-60	0 - 500 L/min	0-5 VDC/ 0-5 VDC	\$1430.00
Stainless Steel with No Display			
6AGC6SN5I-60	0 - 500 L/min	0-5 VDC/ 0-5 VDC	\$2120.00
Stainless Steel with Display			
6AGC6SL5I-60	0 - 200 L/min	0-5 VDC/ 0-5 VDC	\$2200.00

**TABLE 46-6 GC7 HIGH RANGE
MASS FLOW CONTROLLER**

OXYGEN			
MODEL NO.	FLOW RATE	INPUT/OUTPUT	PRICE
Aluminum with No Display			
6AGC7AN5I-70	0 - 1000 L/min	0-5 VDC/ 0-5 VDC	\$1740.00
Aluminum with Display			
6AGC7AL5I-70	0 - 1000 L/min	0-5 VDC/ 0-5 VDC	\$1820.00
Stainless Steel with No Display			
6AGC7SN5I-70	0 - 1000 L/min	0-5 VDC/ 0-5 VDC	\$2720.00
Stainless Steel with Display			
6AGC7SL5I-70	0 - 1000 L/min	0-5 VDC/ 0-5 VDC	\$2800.00

MASS FLOW CONTROLLERS

GC Mass Flow Models Controller Models for Carbon Dioxide

TABLE 47-1 GC1 LOW RANGE MASS FLOW CONTROLLER			
CARBON DIOXIDE			
MODEL NO.	FLOW RATE	INPUT/OUTPUT	PRICE
Aluminum With No Display			
6AGC1AN410-01	0 - 10 mL/min	4-20mA/ 4-20mA	\$695.00
6AGC1AN410-02	0 - 20 mL/min		
6AGC1AN410-03	0 - 50 mL/min		
6AGC1AN410-04	0 - 100 mL/min		
6AGC1AN410-05	0 - 200 mL/min		
6AGC1AN410-06	0 - 500 mL/min		
6AGC1AN410-07	0 - 1 L/min		
6AGC1AN410-08	0 - 2 L/min		
6AGC1AN410-09	0 - 5 L/min		
6AGC1AN410-10	0 - 10 L/min		
Aluminum With Display			
6AGC1AL410-01	0 - 10 mL/min	4-20mA/ 4-20mA	\$775.00
6AGC1AL410-02	0 - 20 mL/min		
6AGC1AL410-03	0 - 50 mL/min		
6AGC1AL410-04	0 - 100 mL/min		
6AGC1AL410-05	0 - 200 mL/min		
6AGC1AL410-06	0 - 500 mL/min		
6AGC1AL410-07	0 - 1 L/min		
6AGC1AL410-08	0 - 2 L/min		
6AGC1AL410-09	0 - 5 L/min		
6AGC1AL410-10	0 - 10 L/min		
Stainless Steel with No Display			
6AGC1SN410-01	0 - 10 mL/min	4-20mA/ 4-20mA	\$860.00
6AGC1SN410-02	0 - 20 mL/min		
6AGC1SN410-03	0 - 50 mL/min		
6AGC1SN410-04	0 - 100 mL/min		
6AGC1SN410-05	0 - 200 mL/min		
6AGC1SN410-06	0 - 500 mL/min		
6AGC1SN410-07	0 - 1 L/min		
6AGC1SN410-08	0 - 2 L/min		
6AGC1SN410-09	0 - 5 L/min		
6AGC1SN410-10	0 - 10 L/min		
Stainless Steel with Display			
6AGC1SL410-01	0 - 10 mL/min	4-20mA/ 4-20mA	\$940.00
6AGC1SL410-02	0 - 20 mL/min		
6AGC1SL410-03	0 - 50 mL/min		
6AGC1SL410-04	0 - 100 mL/min		
6AGC1SL410-05	0 - 200 mL/min		
6AGC1SL410-06	0 - 500 mL/min		
6AGC1SL410-07	0 - 1 L/min		
6AGC1SL410-08	0 - 2 L/min		
6AGC1SL410-09	0 - 5 L/min		
6AGC1SL410-10	0 - 10 L/min		

TABLE 47-2 GC3 MEDIUM RANGE MASS FLOW CONTROLLER			
CARBON DIOXIDE			
MODEL NO.	FLOW RATE	INPUT/OUTPUT	PRICE
Aluminum with No Display			
6AGC3AN410-29	0 - 15 L/min	4-20mA/ 4-20mA	\$860.00
6AGC3AN410-30	0 - 20 L/min		
6AGC3AN410-31	0 - 30 L/min		
6AGC3AN410-32	0 - 40 L/min		
6AGC3AN410-33	0 - 50 L/min		
Aluminum with Display			
6AGC3AL410-29	0 - 15 L/min	4-20mA/ 4-20mA	\$940.00
6AGC3AL410-30	0 - 20 L/min		
6AGC3AL410-31	0 - 30 L/min		
6AGC3AL410-32	0 - 40 L/min		
6AGC3AL410-33	0 - 50 L/min		
Stainless Steel with No Display			
6AGC3SN410-29	0 - 15 L/min	4-20mA/ 4-20mA	\$1060.00
6AGC3SN410-30	0 - 20 L/min		
6AGC3SN410-31	0 - 30 L/min		
6AGC3SN410-32	0 - 40 L/min		
6AGC3SN410-33	0 - 50 L/min		
Stainless Steel with Display			
6AGC3SL410-29	0 - 15 L/min	4-20mA/ 4-20mA	\$1140.00
6AGC3SL410-30	0 - 20 L/min		
6AGC3SL410-31	0 - 30 L/min		
6AGC3SL410-32	0 - 40 L/min		
6AGC3SL410-33	0 - 50 L/min		

TABLE 47-3 GC4 MEDIUM RANGE MASS FLOW CONTROLLER			
CARBON DIOXIDE			
MODEL NO.	FLOW RATE	INPUT/OUTPUT	PRICE
Aluminum with No Display			
6AGC4AN410-40	0 - 60 L/min	4-20mA/ 4-20mA	\$1010.00
6AGC4AN410-41	0 - 80 L/min		
6AGC4AN410-42	0 - 100 L/min		
Aluminum with Display			
6AGC4AL410-40	0 - 60 L/min	4-20mA/ 4-20mA	\$1090.00
6AGC4AL410-41	0 - 80 L/min		
6AGC4AL410-42	0 - 100 L/min		
Stainless Steel with No Display			
6AGC4SN410-40	0 - 60 L/min	4-20mA/ 4-20mA	\$1210.00
6AGC4SN410-41	0 - 80 L/min		
6AGC4SN410-42	0 - 100 L/min		
Stainless Steel with Display			
6AGC4SL410-40	0 - 60 L/min	4-20mA/ 4-20mA	\$1290.00
6AGC4SL410-41	0 - 80 L/min		
6AGC4SL410-42	0 - 100 L/min		

TABLE 47-4 GC5 HIGH RANGE MASS FLOW CONTROLLER			
CARBON DIOXIDE			
MODEL NO.	FLOW RATE	INPUT/OUTPUT	PRICE
Aluminum with No Display			
6AGC5AN410-50	0 - 200 L/min	4-20mA/ 4-20mA	\$1155.00
Aluminum with Display			
6AGC5AL410-50	0 - 200 L/min	4-20mA/ 4-20mA	\$1235.00
Stainless Steel with No Display			
6AGC5SN410-50	0 - 200 L/min	4-20mA/ 4-20mA	\$1820.00
Stainless Steel with Display			
6AGC5SL410-50	0 - 200 L/min	4-20mA/ 4-20mA	\$1900.00

TABLE 47-5 GC6 HIGH RANGE MASS FLOW CONTROLLER			
CARBON DIOXIDE			
MODEL NO.	FLOW RATE	INPUT/OUTPUT	PRICE
Aluminum with No Display			
6AGC6AN410-60	0 - 500 L/min	4-20mA/ 4-20mA	\$1350.00
Aluminum with Display			
6AGC6AL410-60	0 - 500 L/min	4-20mA/ 4-20mA	\$1430.00
Stainless Steel with No Display			
6AGC6SN410-60	0 - 500 L/min	4-20mA/ 4-20mA	\$2120.00
Stainless Steel with Display			
6AGC6SL410-60	0 - 500 L/min	4-20mA/ 4-20mA	\$2200.00

TABLE 47-6 GC7 HIGH RANGE MASS FLOW CONTROLLER			
CARBON DIOXIDE			
MODEL NO.	FLOW RATE	INPUT/OUTPUT	PRICE
Aluminum with No Display			
6AGC7AN410-70	0 - 1000 L/min	4-20mA/ 4-20mA	\$1740.00
Aluminum with Display			
6AGC7AL410-70	0 - 1000 L/min	4-20mA/ 4-20mA	\$1820.00
Stainless Steel with No Display			
6AGC7SN410-70	0 - 1000 L/min	4-20mA/ 4-20mA	\$2120.00
Stainless Steel with Display			
6AGC7SL410-70	0 - 1000 L/min	4-20mA/ 4-20mA	\$2800.00

TABLE 48-1 MASS FLOW CONTROLLER ACCESSORIES

MODEL NO.	POWER SUPPLIES	PRICE
6APSGCNA-12	Power Supply 110 vac/12 Vdc (North America)	\$60.00
6APSGCNA-24	Power Supply 110 vac/24Vdc (North America)	\$60.00
6APSGCEU-12	Power Supply 230 vac/12 Vdc (Europe)	\$70.00
6APSGCEU-24	Power Supply 230 vac/24 Vdc (Europe)	\$70.00
6APSGCAU-12	Power Supply 240 vac/12 Vdc (Australia)	\$90.00
6APSGCAU-24	Power Supply 240 vac/24 Vdc (Australia)	\$90.00
6APSGCUK-12	Power Supply 240 vac/12 Vdc (United Kingdom)	\$90.00
6APSGCUK-24	Power Supply 240 vac/24 Vdc (United Kingdom)	\$90.00
CABLE ASSEMBLY		
6ACBLGCD	Shielded cable assembly, 8ft long with 15 pin D-connector unterminated en (\$1.00 each additional foot)	\$45.00
REMOTE READ OUT AND CABLE FOR REMOTE READOUT		
6ARLCDGM-3F	Remote LCD readout, with 3ft cable	\$92.00
6ARCBLGM-3F	Remote cable, 3ft. (\$1.00 each additional foot)	\$20.00

RECHARGEABLE BATTERY KIT



Mass Flow Meter with Rechargeable Battery Kit

In many applications where line voltage is either not available or desirable, the mass flow meter can be used as a portable device. This is accomplished by using an external rechargeable battery kit.

The complete kit includes a battery, recharger and a compact carrying case with shoulder strap and belt loop. With the battery kit, the meter can be used in excess of 40 hours without recharging.

TABLE 48-1 MASS FLOW METER ACCESSORIES

MODEL NO.	POWER SUPPLIES	PRICE
6APSGMNA-12	Power Supply 110 vac/12 Vdc (North America)	\$40.00
6APSGMNA-24	Power Supply 110 vac/24Vdc (North America)	\$63.00
6APSGMEU-12	Power Supply 230 vac/12 Vdc (Europe)	\$57.00
6APSGMEU-24	Power Supply 230 vac/24 Vdc (Europe)	\$57.00
6APSGMAU-12	Power Supply 240 vac/12 Vdc (Australia)	\$57.00
6APSGMAU-24	Power Supply 240 vac/24 Vdc (Australia)	\$57.00
6APSGMUK-12	Power Supply 240 vac/240 Vdc (United Kingdom)	\$57.00
6APSGMUK-24	Power Supply 240 vac/240 Vdc (United Kingdom)	\$57.00
BATTERY KIT WITH RECHARGER		
6ABPGMNA-12	Battery Kit, with recharger (110v)	\$166.00
6ABPGMEU-12	Battery Kit, with recharger (220v)	\$224.00
FEMALE 9 PIN D-CONNECTOR WITH CABLE		
6ACBLGM4-3F	Female 9 pin D-connector, with 3ft cable for connection to MDPC. (4-20 mA)	\$28.00
6ACBLGM4-6F	Female 9 pin D-connector, with 6ft cable for connection to MDPC. (4-20 mA)	\$30.00
6ACBLGM5-3F	Female 9 pin D-connector, with 3ft cable for connection to MDPC. (0 - 5 vdc)	\$28.00
6ACBLGM5-6F	Female 9 pin D-connector, with 6ft cable for connection to MDPC. (0 - 5 vdc)	\$30.00
REMOTE READ OUT AND CABLE FOR REMOTE READOUT		
6ARLCDGM-3F	Remote LCD readout, with 3ft cable	\$92.00
6ARCBLGM-3F	Remote cable, 3ft. (additional cable lengths available) Contact Dakota®.	\$20.00

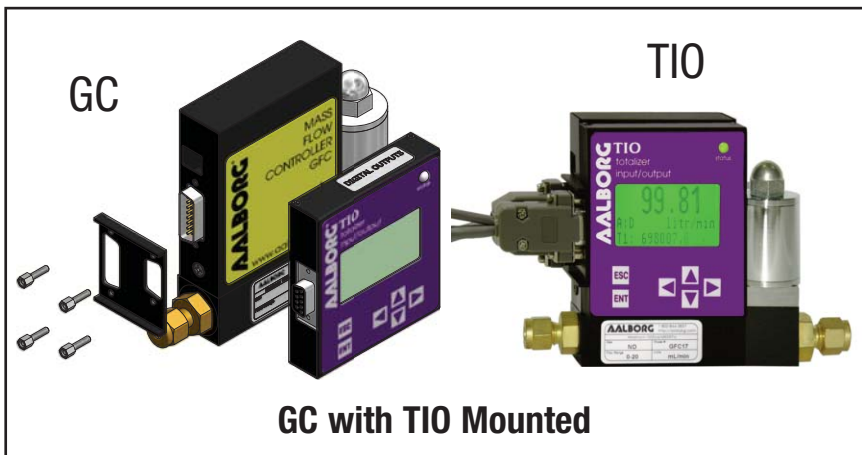

Applications

For flow meters and controllers with analog 0-5 (5-10) (0-10)Vdc, 4-20mA input output interface, where flow indications / control and totalizers or alarm functions are required. Also when re-transmission of the flow rate and/or totalizer functions via optically-isolated pulse output or serial communication is desired. Local or programmable set point control for flow controllers (no host PC presence required). Activation of user-supplied equipment via programmable optically-isolated digital outputs when flow alarms or totalizers events are active.

Display

The graphical LCD display has large 13mm (0.51") digits for flow rate and 5.5mm (0.21") for total and can be set by user to simultaneously show different combination of the flow parameters: flow rate, totalizers, flow alarms, and diagnostic events . All configuration parameter settings are easily accessed via a simple user-interface menu driven by a 6 button key-pad which can be password-protected.

DESIGN FEATURES

- ✓ Displays instantaneous, total and accumulated flow rates.
- ✓ Built-in Flow Linearizer (10 point linearization of the flow curve).
- ✓ Up to 47 different volumetric and mass flow engineering units.
- ✓ Large 13mm (0.51") digits for flow rate and 5.5mm (0.21") for Total.
- ✓ Digital RS-232 or RS-485 interface (multi-drop capability of up to 64 devices.)
- ✓ Compact design for unit mount, panel mount, wall mount or field mount applications.
- ✓ User-programmable, optically-isolated pulse output.
- ✓ Two programmable, optically-isolated, digital outputs.
- ✓ Flow controllers, set point command control via local LCD or digital interface.
- ✓ Programmable set point table with ramping up/down capability up to 16 steps.
- ✓ Free Configuration and Monitoring Utility software.

Programmable Pulse Output

The programmable flow pulse output is operating independently from totalizers and based on configuration settings can provide pulse frequency proportional to instantaneous fluid flow rate.

The LCD/keypad and digital communication interface commands are provided to:

- ✓ Enable/Disable Pulse Output.
- ✓ Configure Pulse Output start flow rate (in % of full scale).
- ✓ Configure the Unit/Pulse value (in current volumetric or mass flow units).
- ✓ Configure Pulse Active On Time (10 - 6550 ms).

Signal Input and Signal Output

- ✓ 0-5 Vdc (Input/Output)
- ✓ 5-10 Vdc (Output only)
- ✓ 0-10 Vdc (Input/Output)
- ✓ 4-20 mA (Input/Output)

For flow meters and / or flow controllers, TIO provides jumpers selectable for 0-5 Vdc or 4-20 mA analog set point control signals. The flow rate set point can be adjusted locally via key-pad, remotely via host PC using digital communication interface, or programmed in advance using built-in 16 steps batch table with ramping up/down support.

Digital Communication

All process data and settings can be read and modified manually via local LCD Key-pad or through the digital RS-232 or RS-485 communication interface. Proprietary ASCII software interface command set and free Communication Utility software are provided.

Programmable Totalizers

TIO provides two independent programmable flow totalizers. Both totalizers are updated every 100 ms and can be set to activate different events. Main totalizer accumulated total is backed-up in EEPROM memory every second.

The LCD/keypad and digital communication interface commands are provided to:

- ✓ Enable/Disable totalizing the flow.
- ✓ Start the totalizer at a preset flow rate (in % of full scale).
- ✓ Assign action at a preset total volume (Event Volume).
- ✓ Configure power on delay (in seconds).
- ✓ Configure Auto Reset at preset volume.
- ✓ Configure Auto Reset delay (in seconds).
- ✓ Reset the totalizer to ZERO.

Programmable Alarms

TIO provides the user with a flexible alarm/warning system that monitors the fluid flow for conditions that fall outside configurable limits as well as visual feedback for the user via the LCD or via an optically-isolated output. The flow alarm has several attributes which can be configured by the user via LCD/Keypad or digital communication interface:

- ✓ Enable/Disable flow alarm.
- ✓ Low flow alarm settings (in % of full scale).
- ✓ High flow alarm settings (in % of full scale).
- ✓ Flow alarm action delay.
- ✓ Flow alarm action latch mode.



*SPECIFICATIONS

ADC/DAC RESOLUTION:	12 bit.
ANALOG INPUTS:	0-5 Vdc, 4-20 mA, 5-10 Vdc (jumper-selectable), 0-10 Vdc (special order).
ANALOG OUTPUTS:	0-5 Vdc, 4-20 mA (jumper-selectable).
LCD:	128x64 graphic LCD with instantaneous Flow reading and Total volume indication. Adjustable LCD contrast and back light.
KEY-PAD:	Local 6 tactical push buttons.
PULSE OUTPUT:	User-programmable, optically-isolated, with preset active low time interval (10 – 6550 ms).
DIGITAL OUTPUT:	Two programmable, optically-isolated, UCE @ 40Vdc, ICE @ 150 mA (Voltage Isolation: 250 Vrms).
DIGITAL INTERFACE:	RS-232 or RS-485 (multidrop capability up to 64 devices).
PROTOCOL:	Proprietary ASCII software interface command set.
SPEED:	1200 - 2400 - 4800 - 9600 -19200 – 38400 – 57600 – 115200 baud (user selectable).
CONFIGURATION:	Stop bit: 1 Data bits: 8 Parity: None Flow Control: None
ADDRESSING:	Maximum 255 addresses (for RS-485 option only).
TYPE:	RS232 or RS485 2-wire.
POWER REQUIREMENTS:	12 – 26 Vdc (up to 60 mA maximum).
INTERFACE CONNECTORS:	Process I/O signals and Digital RS-232/RS-485 interface – miniature 9 pin female D-SUB connector. Digital optically-isolated outputs: TERM BLOCK HEADER 4POS 3.5MM Male Pins, Shrouded.
ENVIRONMENT:	Installation Level II, Pollution Degree II, (Per IEC 664).
ELECTROMAGNETIC COMPATIBILITY:	Compliant ref. 89/336/EEC as amended. Emission Standard: EN 55011:1991, Group 1, Class A Immunity Standard: EN 55082- 1:1992
OPERATING TEMPERATURE:	-10 °C to +70 °C (14°F to +158 °F).
DIMENSIONS:	86.4 x 76.2 x 19.1 mm (3.4" x 3.0" x 0.75") - W x H x D.
WEIGHT:	Appr. 125g / 0.3 lbs.

* The selection of materials of construction, is the responsibility of the customer. The company accepts no liability.

Totalizer input/output Flow Monitor/Controller

TABLE 51 TIO ACCESSORY'S		
PART NUMBER	DESCRIPTION	WHEN REQUIRED
KIT-TM-DD	GM flow meter mounting kit, shielded cable with two 9 pins D-connectors for process signals and communication branch.	GM + digital communication with Host PC or PLC.
KIT-TM-RD	GM flow meter mounting kit, 4 wire cable between GM RJ11 and TIO 9 pin D-connector.	GM (12 Vdc power option only), 5-10 Vdc input, no digital communication.
KIT-TM-FD	GM flow meter mounting kit, flat wire cable between GM and TIO 9 pin D-connectors.	GM, 0-5Vdc input no digital communication.
KIT-TC-110NA-2C	GC flow controller mounting kit, shielded cable with North America plug 110 Vac to 12 Vdc power supply, communication branch.	GC, 0-5 Vdc input, North America 12 Vdc power supply, digital communication.
KIT-TC-110NA-2N	GC flow controller mounting kit, shielded cable with North America plug 110 Vac to 12 Vdc power supply.	GC, 0-5 Vdc input, North America 12 Vdc power supply.
KIT-TC-110NA-4C	GC flow controller mounting kit, shielded cable with North America plug 110 Vac to 24 Vdc power supply, communication branch.	GC, 0-5 Vdc input, North America 12 Vdc power supply.
KIT-TC-110NA-4N	GC flow controller mounting kit, shielded cable with North America plug 110 Vac to 24 Vdc power supply.	GC, 0-5 Vdc input, North America 24 Vdc power supply.
KIT-TC-230EU-2C	GC flow controller mounting kit, shielded cable with EUROPE plug 230 Vac to 12 Vdc power supply, communication branch.	GC, 0-5 Vdc input, Europe 12 Vdc power supply, digital communication.
KIT-TC-230EU -2N	GC flow controller mounting kit, shielded cable with EUROPE plug 230 Vac to 12 Vdc power supply.	GC, 0-5 Vdc input, Europe 12 Vdc power supply.
KIT-TC-230EU -4C	GC flow controller mounting kit, shielded cable with EUROPE plug 230 Vac to 24 Vdc power supply, communication branch.	GC, 0-5 Vdc input, Europe 24 Vdc power supply, digital communication.
KIT-TC-230EU -4N	GC flow controller mounting kit, shielded cable with EUROPE plug 230 Vac to 24 Vdc power supply.	GC, 0-5 Vdc input, Europe 24 Vdc power supply.
KIT-TC-240AU-2C	GC flow controller mounting kit, shielded cable with AUSTRALIA plug 240 Vac to 12 Vdc power supply, communication branch.	GC, 0-5 Vdc input, Australia 12 Vdc power supply, digital communication.
KIT-TC-240AU-2N	GC flow controller mounting kit, shielded cable with AUSTRALIA plug 240 Vac to 12 Vdc power supply.	GC, 0-5 Vdc input, Australia 12 Vdc power supply.
KIT-TC-240AU-4C	GC flow controller mounting kit, shielded cable with AUSTRALIA plug 240 Vac to 24 Vdc power supply, communication branch.	GC, 0-5 Vdc input, Australia 24 Vdc power supply, digital communication.
KIT-TC-240AU-4N	GC flow controller mounting kit, shielded cable with AUSTRALIA plug 240 Vac to 12 Vdc power supply.	GC, 0-5 Vdc input, Australia 24 Vdc power supply.
KIT-TC-240UK-2C	GC flow controller mounting kit, shielded cable with UK plug 240 Vac to 12 Vdc power supply, communication branch.	GC, 0-5 Vdc input, UK 12 Vdc power supply, digital communication.
KIT-TC-240UK -2N	GC flow controller mounting kit, shielded cable with UK plug 240 Vac to 12 Vdc power supply.	GC, 0-5 Vdc input, UK 12 Vdc power supply.
KIT-TC-240UK -4C	GC flow controller mounting kit, shielded cable with UK plug 240 Vac to 24 Vdc power supply, communication branch.	GC, 0-5 Vdc input, UK 24 Vdc power supply, digital communication.
KIT-TC-240UK-4N	GC flow controller mounting kit, shielded cable with UK plug 240 Vac to 24 Vdc power supply.	GC, 0-5 Vdc input, UK 24 Vdc power supply.
KIT-TC-240UK-2AC	GC flow controller mounting kit, shielded cable with UK plug 240 Vac to 12 Vdc power supply, communication branch, analog 4-20 mA output branch from GC.	GC, 0-5 Vdc input, UK 12 Vdc power supply, digital communication, analog 4-20 mA output branch from GC.
KIT-TC-240UK-4AC	GC flow controller mounting kit, shielded cable with UK plug 240 Vac to 24 Vdc power supply, communication branch, analog 4-20 mA output branch from GC.	GC, 0-5 Vdc input, UK 24 Vdc power supply, digital communication, analog 4-20 mA output branch from GC.
KIT-TM	GM flow meter mounting kit, no cables.	GM, user-supplied custom cables.
KIT-TC	GC flow controller mounting kit, no cables.	GC, user-supplied custom cables.
CBL-DA9-X	9 conductor round shielded cable consisting of a 9 pin Female "D" Sub-Connector (plug) on one end, and loose wires on the other end.	For TIO stand alone option, user-supplied power supply.

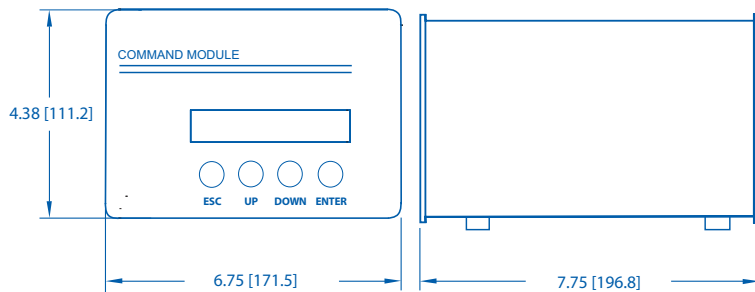

DIMENSIONS SHOWN IN BRACKETS ARE IN MILLIMETERS

SDPROC

Microprocessor driven digital Command Modules are used in conjunction with any analog or digital mass flow meters or controllers with 0-5 Vdc input /output signals. One, two, three and four channel Command Module configurations are available. Command Modules contain appropriate power supplies, 24x2 alpha-numeric dot matrix display readout, and four panel buttons which provide complete control over all the various functions necessary to measure and/or control flow.

PROGRAMMING

It is easy to program the SMART DPROC using a logically organized, modular menu. The operator quickly accesses a desired function by branching through the multi-level tree structure, rather than scrolling through the entire menu. RS-232 serial communication interface is standard for all models and supported via a 9 pin "D"-connector on the back panel of the Command Module. RS-232 Software interface commands set allows communications with the unit using either a custom software program or a "dumb terminal" and provide complete control over all modes and functions.

PROGRAMMABLE BATCH FLOW CONTROL

The Batch Flow Control allows execution of custom, user preset program of up to sixteen steps. During execution of the program the user can activate or deactivate the LOOP mode. Various flow configurations may be preprogrammed: ramping, pulsing, linearized increasing and/or decreasing of the flow. Optional built-in Ethernet interface allows accessing any Internet-connected SDPROC from a browser on your work station, PC, or laptop computer.

Regardless of where you are, your Command Module is as close as the nearest browser! There are two levels of Ethernet based Remote Controls: HTML web server and TELNET. The HTML web server, which is hosted on the Command Module lets one view CURRENT FLOW RATE, CONTROL VALVE MODE and/or SET POINT, MONITOR TOTALIZER READING FOR SELECTED CHANNEL. The TELNET console provides complete control over all modes and functions and using the same Software interface commands set as the RS-232 communication interface.

DESIGN FEATURES

ENGINEERING UNITS

The flow set points, measured gas flow and associated totalizer data are scaled directly in engineering units via front panel keypad, RS-232 or Ethernet interface.

The following units of measure are supported: %F.S., SLPM, L/s, mL/min, mL/h, SCFM, SCFH, SCMM, SCMh, LBPM, LBPH, GRPM, GRPH.

USER SELECTABLE REFERENCE FOR SET POINT

The INTERNAL, EXTERNAL, PROGRAM refers to the point of origin for the Set Point signal.

In INTERNAL REFERENCE MODE, the user sets the control signal with SDPROC controls (via front panel keypad, RS-232 or Ethernet interface).

In EXTERNAL REFERENCE MODE, the user sets the control signal from a remote location (via the DATA IN/OUT 25-pin "D"-connector on the rear panel).

In PROGRAM MODE the set point signal will be driven by user's custom program stored in the EEPROM. There are three Program modes: BATCH, TIMER and RATIO*.

*RATIO mode not available for one channel module.

PROGRAMMABLE TIMER FLOW CONTROL

The Timer Flow Control allows execution of custom, user pre-set program of up to 96 steps.

Each step can be preprogrammed for a particular date, time, and set point value. Every step has two fields: starting date, time and set point in % F.S.

RATIO FLOW CONTROL

The Ratio Flow allows controlling flow of the mixture of up to four different gases (for 4 channel Command Module) with preset values of the ratio in % for each channel. The flow rate of the mixture can be incremented or decremented by changing the set point of the master channel #1.

FLOW ALARMS

High and Low gas flow ALARM limits can be preprogrammed for each channel. ALARM conditions become true when the difference between current readings and installed set points are equal or more than corresponding values of high and low alarm levels.

Alarm action can be assigned with preset delay interval (0-3600 seconds) to one of the following:

- Contact closer (separate for High and Low alarm).
- Buzzer audible signal.
- Valve shut down (Close).

CONTACT CLOSURES

Two sets of dry contact relay outputs for each channel are provided to actuate user supplied equipment. The relays can be assigned to switch when a specified event occurs (e.g. when a low or high flow alarm limit is exceeded or when the totalizer reaches a specified value).

TOTALIZER

The total volume of the gas is calculated by integrating the actual gas flow rate with respect to time.

Both keypad menu and digital interface commands are provided to:

- Set the totalizer to ZERO.
- Start the totalizer at a preset flow.
- Assign action at a preset total volume.
- Start/Stop totalizing the flow.
- Read totalizer.

Totalizer conditions become true, when the totalizer, and the "Stop at Total" volumes are equal.

Totalizer action can be assigned to one of the following:

- Contact closer.
- Buzzer audible signal.
- Valve shut down (Close).

*SPECIFICATIONS

ENVIRONMENTAL: Installation Level II; Pollution degree II.
(per IEC 664)

POWER SUPPLY: 85 to 240 VAC (47 to 440 Hz); 120 to 370 VDC 2A max.

FUSE: 2A on input power line. When changing, unplug the device from power source. Replace only with fuse 5mm 2A/250V FF.

DISPLAY: 24 x 2 LCD dot matrix with backlight; 24x2 Vacuum Fluorescent display optional.

ADC/DAC RESOLUTION:
12 bits (0.025%).

COMMUNICATION STANDARD:
RS-232 9600 baud rate, 8 bits, two stop bits, no parity (8,2.N).

OPTIONAL: Ethernet TCP/IP. (HTML Server or TELNET Console).

DIMENSIONS: Length: 7.75" (19.5 cm), width: 6.75" (17 cm), height: 4.5" (11cm).

WEIGHT: 4.5 lbs (2 kg).

INTERFACE CABLE: Flat cable with male 15-pin "D" connector and female 15-pin "D" connector on the ends is standard. Optional round shielded cable is available with male/female 15-pin "D" connector ends. [Cable length may not exceed 9.5 feet (3 meters)].

DATA PORT AND RELAY CABLE:
Optional shielded cable with male 25-pin "D" connector to connect to command module data and relay ports. [Cable length may not exceed 9.5 feet (3 meters)].

* The selection of materials of construction, is the responsibility of the customer. The company accepts no liability.

DIGITAL MASS FLOW CONTROLLERS



DESIGN FEATURES

- ✓ Digital and Analog modes operate simultaneously.
- ✓ Programmable Flow Configurations.
- ✓ Multi-Drop Capability of up to 256 units.
- ✓ Stores calibration data for up to 10 gases.
- ✓ Totalizer indicates total gas quantity.
- ✓ Alarm limits for high and low gas flow.
- ✓ Conversion factors for up to 256 gases.
- ✓ Auto Tune function for optimum control response.
- ✓ Self Diagnostic Tests.

TOTALIZER

The firmware for the digital mass flow controller provides functions to register total gas quantity. The total mass of gas is calculated by integrating the actual gas flow rate with respect to time.

Digital interface commands are provided to:

- ✓ SET the totalizer to ZERO.
- ✓ START /STOP totalizing the flow.
- ✓ READ the totalizer.
- ✓ START the totalizer at a preset flow.
- ✓ STOP the flow at a preset total.

Microprocessor driven digital flow controllers allow one to program, record, and analyze flow rates of various gases with a computer via an RS-485 interface (optional RS-232 is available).

Controllers can be programmed for various control functions including flow set point, totalizer, stop totalizer, read totalizer, totalizer from preset flow, stop at preset total, auto zero, and more.

PRINCIPLES OF OPERATION

Metered gases are divided into two laminar flow paths, one through the primary flow conduit, and the other through a capillary sensor tube. Both flow conduits are designed to ensure laminar flows and therefore the ratio of their flow rates is constant. Two precision temperature sensing windings on the sensor tube are heated, and when flow takes place, gas carries heat from the upstream to the downstream windings. The resultant temperature differential is proportional to the change in resistance of the sensor windings.

An on-board microprocessor and non-volatile memory store all calibration factors and directly control a proportionating electro-magnetic valve. The digital closed loop control system continuously compares the mass flow output with the selected flow rate. Deviations from the set point are corrected by compensating valve adjustments, with PID algorithm thus maintaining the desired flow parameters with a high degree of accuracy. Output signals of 0 to 5 Vdc or 4 to 20mA are generated indicating mass molecular based flow rates of the metered gas.

INTERFACE

The **digital interface** operates via RS485 (optional RS232) and provides access to applicable internal data including FLOW SET POINT, ACTUAL FLOW, ZERO ADJUSTMENTS, and LINEARIZATION TABLE ADJUSTMENTS. The analog interface provides 0 to 5 Vdc, 0 to 10 Vdc and 4 to 20 mA inputs and outputs.

AUTO ZERO

The digital mass flow controller automatically nulls the sensor zero offset whenever the flow set point is below 2% of full scale. To accommodate this feature the control valve must fully close under that condition. Provisions are made to either disable, force or store the current auto zero via digital commands.

*SPECIFICATIONS

ACCURACY:	±1% of FS at calibration temperature and pressure.
CALIBRATIONS:	Performed at standard conditions [14.7 psia (101.4 kPa) and 70 °F (21.1 °C)] unless otherwise requested.
REPEATABILITY:	±0.15% of full scale.
RESPONSE TIME:	1.0 to 2.0 second to within ±2% of set point over 20% to 100% of full scale.
TEMPERATURE COEFFICIENT:	0.05% of full scale/ °F or better.
PRESSURE COEFFICIENT:	0.01% of full scale /psi (0.07 bar) or better.
OPTIMUM GAS PRESSURE:	25 psig (1.73 bars).
MAXIMUM GAS PRESSURE:	1000 psig (70 bars).
MAXIMUM DIFFERENTIAL PRESSURE:	50 psig (3.4 bars) for DC 26 and DC 36 40 psig (2.8 bars) for DC 46.
MAX PRESSURE DROP:	Refer to Maximum Pressure Drop Table.
GAS and AMBIENT TEMP:	32 °F to 122 °F (0 °C to 50 °C). 14 °F to 122 °F (-10 °C to 50 °C) - Dry gases only.
COMMUNICATION INTERFACE:	RS485 - Standard. RS232 - Optional.
OUTPUT SIGNALS:	Linear 0-5 Vdc (2000 ohms min load impedance); impedance); 0-10Vdc (4000 ohms min impedance); 4-20 mA optional (0-500 ohms\ loop resistance). Maximum noise 20mV peak to peak.
CIRCUIT PROTECTION:	Circuit boards have built-in polarity reversal protection. Resettable fuses provide power input protection.
**MATERIALS IN FLUID CONTACT:	316 stainless steel, 416 stainless steel, Viton® O-rings. Optional O-rings: Buna®, EPR and Kalrez®.
ATTITUDE SENSITIVITY:	No greater than +15 degree rotation from horizontal to vertical; standard calibration is in horizontal position.
CONNECTIONS:	Model DC 26/36: Standard 1/4" compression fittings. Optional: 6mm compression fittings or 3/8" compression fittings or 1/4" VCR® or 1/8" compression fittings (DC 26). Model DC 46: standard 3/8" compression fittings.
LEAK INTEGRITY:	1 x 10 ⁻⁹ sml/sec of helium maximum to the outside environment.
TRANSDUCER INPUT POWER:	±15Vdc, 450 mA maximum.
CALIBRATION OPTIONS:	Standard 10 point NIST traceable calibration. Optional up to 9 additional 10 point calibrations may be ordered for an additional charge.
CE COMPLIANCE:	EN 55011 class 1, class B; EN50082-1.

* The selection of materials of construction, is the responsibility of the customer. The company accepts no liability.

DIGITAL MASS FLOW CONTROLLERS

Model **AC** and **AM** mass flow meters and controllers are designed to indicate flow rates and control set flow rates of gases.

Each of these units incorporates an advanced straight tube sensor in conjunction with flow passage elements constructed of stainless steel.

LED readouts of command modules are supplied with 0 to 100 percent calibrations. Zero and span adjustments are conveniently accessible from outside of the transmitters.

GENERAL DESCRIPTION

AC mass flow controllers include an electromagnetic control valve that allows the flow to be set to any desired flow rate within the range of the particular model. The valve is normally closed as a safety feature to ensure that gas flow is shut off in case of a power outage.

AF mass flow meters and controllers are designed to meter and control flow rates of gases.

AF mass flow meters and controllers are available with flow ranges from 10 sccm to 100LPM [N₂]. Gases are connected by means of 1/4", 3/8", or optional 1/8" compression fittings. These controllers may be used as bench top units or mounted by means of screws in the base.

Transducer power supply ports are fuse and polarity protected.

PRINCIPLES OF OPERATION

Metered gases are divided into two laminar flow paths, one through the primary flow conduit, and the other through a capillary sensor tube. Both flow conduits are designed to ensure laminar flows and therefore the ratio of their flow rates is constant.

Two precision temperature sensing windings on the sensor tube are heated, and when flow takes place, gas carries heat from the upstream to the downstream windings. The resultant temperature differential is proportional to the change in resistance of the sensor windings.

*SPECIFICATIONS FOR MASS FLOW METERS AND CONTROLLERS

ACCURACY:	±1% of full scale, including linearity for gas temperatures ranging from 59 °F to 77 °F (15 °C to 25 °C) and pressures of 10 to 60 psia (0.7 to 4.1 bars); ±2% of full scale including linearity ranging from 41 °F to 122 °F (5 °C to 50 °C) and pressures of 5 to 150 psia (0.35 to 10.3 bars).
REPEATABILITY:	±0.2% of full scale.
TIME CONSTANT:	AM Series - 300 ms AC2600 (Q _{max} = 15 sL/min) - 300 ms AC3600 (Q _{max} = 50 sL/min) - 600 ms AC4600 (Q _{max} = 100 sL/min) - 600 ms
RESPONSE TIME:	AM Series - Approximately 1 second to within ±2% of set flow rate for 25% to 100% of full scale flow. AC2600 (Q _{max} = 15 sL/min) - Approximately 1 second to within ±2% of set flow rate for 25% to 100% of full scale flow. AC3600 (Q _{max} = 50 sL/min) and AC4600 (Q _{max} = 100 sL/min) - Approximately 2 second to within ±2% of set flow rate for 25% to 100% of full scale flow.
TEMPERATURE COEFFICIENT:	0.1% of full scale/ °C.
PRESSURE COEFFICIENT:	0.01% of full scale/psi (0.07 bar).
OPTIMUM GAS PRESSURE:	25 psig (1.73 bars).
MAXIMUM GAS PRESSURE:	500 psig (34.5 bars) maximum. Standard calibration is at 20 psig (1.4 bars) inlet pressure.
MAX. PRESSURE DROP: [cm H ₂ O] (at full scale flow):	Refer to Table 53-1 and 53-2.
GAS AND AMBIENT TEMP:	41°F to 122°F (5°C to 50°C).
LEAK INTEGRITY:	1 x 10 ⁻⁹ sL/sec of helium maximum, to the outside environment.
MATERIALS IN FLUID CONTACT:	316 stainless steel, 416 stainless steel, Viton® O-rings. Optional o-rings, Neoprene®, or Kalrez®.
ATTITUDE SENSITIVITY:	No greater than ±15 degree rotation from horizontal to vertical; standard calibration is in horizontal position.
OUTPUT SIGNALS:	Linear 0 - 5 Vdc (2000Ω min. load impedance); 4 - 20 mA optional (0 - 500Ω loop resistance); maximum noise 20 mV peak to peak.
CONNECTIONS:	AM/AC2600, AM/AC3600 - 1/4" compression fittings, AM/AC4600 - 3/8" compression fittings. Optional - 1/8" or 3/8" compression fittings or 1/4" VCR® fittings.
TRANSDUCER INPUT POWER:	AM/AC2600 +15 ± 5% Vdc, 80 mA max, 1.2W; -15 ± 5% Vdc, 200 mA max, 3W; AC3600/AC4600 +15 ± 5% Vdc, 220 mA max, 3.3W; -15 ± 5% Vdc, 600 mA max, 9W.
CIRCUIT PROTECTION:	Circuit boards have built-in polarity reversal protection. Replaceable fuses provide power input protection.

* The selection of materials of construction, is the responsibility of the customer. The company accepts no liability.

Output signals of 0 to 5 Vdc or 4 to 20mA are generated indicating mass molecular based flow rates of the metered gas. In AC mass flow controllers the combined gas streams flow through a proportionating electromagnetic valve with an appropriately selected orifice. The closed loop control circuit continuously monitors the mass flow output and maintains it at the set flow rate.

MULTI-GAS CALIBRATION

The DC is capable of storing primary calibration data for up to 10 gases. This feature allows the same DC to be calibrated for multiple gases while maintaining the rated accuracy on each.

CONVERSION FACTORS

Conversion factors for up to 256 gases are stored in the DC. Conversion factors may be applied to any of the ten gas calibrations via digital interface commands.

FLOW ALARMS

High and Low gas flow ALARM limits are programmed using the digital interface. Alarm conditions are reported via the digital interface or can activate the contact closure outputs.

PROGRAMMABLE FLOW

Dakota® software supports programmable flow modes, allowing execution of custom programming of up to ten steps. Various flow configurations include ramping, linearized increasing and decreasing modes.

AUTO TUNE

The AUTO TUNE function allows the DC to automatically optimize control response for the gas under actual process conditions. During the AUTO TUNE process, the instrument adjusts PID gains for optimum step response and determine key control valve characteristics (only available on units with less than 80 L/min maximum flow).

CONTACT CLOSURE

Two sets of dry contact relay outputs are provided to actuate user supplied equipment. These are programmable via the digital interface such that the relays can be made to switch when a specified event occurs (e.g. when a low or high flow alarm limit is exceeded or when the totalizer reaches a specified value).

VALVE OVERRIDE

Means are provided to force the control valve fully open (purge) or fully closed via either the analog or digital interfaces.

SELF DIAGNOSTICS

Whenever power is first applied, the digital mass flow controller runs a series of SELF DIAGNOSTIC TESTS to ensure that it is in optimum working condition.

ENGINEERING UNITS

The flow set point, measured gas flow and associated totalizer data is scaled directly in engineering units via digital interface commands. The following units of measure are supported: % of FS, mL/min, mL/hr, scfm, scfh, sL/min, sL/hr, lbs/hr, lbs/min, and one user defined unit of measure.

BALANCED POWER SUPPLY

The digital mass flow controller operates on ±15Vdc. The current requirements for the positive and negative power supplies are balanced such that the current in the power supply common connection is minimized. Maximum power consumption is 13.5 watts at ±15Vdc.

LEAK INTEGRITY

1 x 10⁻⁹ sL/sec of Helium maximum to the outside environment.

TABLE 53-1 FLOW RANGES FOR DC	
DC 26 LOW FLOW CONTROLLERS	
CODE	Units [Nitrogen]
01	0 to 10 sL/min
02	0 to 20 sL/min
03	0 to 50 sL/min
04	0 to 100 sL/min
05	0 to 200 sL/min
06	0 to 500 sL/min
07	0 to 1 sL/min
08	0 to 2 sL/min
09	0 to 5 sL/min
10	0 to 10 sL/min
DC 36 MEDIUM FLOW CONTROLLERS	
CODE	sL/min [N ₂]
11	0 to 15 sL/min
30	0 to 20 sL/min
31	0 to 30 sL/min
32	0 to 40 sL/min
33	0 to 50 sL/min
DC 46 HIGH MASS FLOW CONTROLLERS	
CODE	sL/min [N ₂]
40	0 to 60 sL/min
41	0 to 80 sL/min
42	0 to 100 sL/min

Model Selections Page 54

TABLE 53-2 MAXIMUM PRESSURE DROP FOR DC				
MODEL NO.	MAX. FLOW (N ₂)	MAXIMUM PRESSURE DROP		
		[mm H ₂ O]	[psid]	[mbar]
DC 26	up to 10	720	1.06	75
DC 36	15	2630	3.87	266
	20	1360	2.00	138
	30	2380	3.50	241
	40	3740	5.50	379
	50	5440	8.00	551
DC 46	60	7480	11.00	758
	100	12850	18.89	1302

TABLE 53-3 DIGITAL MASS FLOW METER ACCESSORIES		
MODEL NO.	POWER SUPPLIES	PRICE
6APSDCNA-15D	Power Supply, 25 pin D-connector, Standard Interface 110/vac (+ - 15 Vdc.) (North America)	\$214.00
6APSDCNA-15A	Power Supply, 25 pin D-connector, Analog Interface 110/vac (+ - 15 Vdc.) (North America)	\$250.00
6APSDCEU-15D	Power Supply, 25 pin D-connector, Standard Interface 230/vac (+ - 15 Vdc.) (Europe)	\$214.00
6APSDCEU-15A	Power Supply, 25 pin D-connector, Analog Interface 230/vac (+ - 15 Vdc.) (Europe)	\$250.00
6APSDCAU-15D	Power Supply, 25 pin D-connector, Standard Interface 240/vac (+ - 15 Vdc.) (Australia)	\$214.00
6APSDCAU-15A	Power Supply, 25 pin D-connector, Analog Interface 240/vac (+ - 15 Vdc.) (Australia)	\$250.00
6APSDCUK-15D	Power supply, 25 pin D-connector, Standard Interface 240/vac (+ - 15 Vdc.) (United Kingdom)	\$214.00
6APSDCUK-15A	Power Supply, 25 pin D-connector, Analog Interface 240/vac (+ - 15 Vdc.) (United Kingdom)	\$250.00
D-CONNECTOR		
6ACBLDCD	25 pin D-connector with 6ft Wire to Computer Port Stripped, Branch 3ft Wire to Power Supply.	\$57.00
6ACBLDCP	25 pin D-connector with 6ft Wire to 15 pin DM, Branch 6ft Wire to Computer Port Stripped	\$35.00