

# MASS FLOW CONTROLLERS

## MASS FLOW CONTROLLERS

Thermal Mass Flow Controllers are designed to indicate and control set flow rates of gases.

The mass flow controller combines the characteristics, and accuracy of conventional mass flow devices into a unique compact design at low costs previously unattainable.

Each of these controllers incorporates an advanced straight tube sensor in conjunction with flow passage elements constructed of aluminum and brass for non-corrosive gases or 316 stainless steel for corrosive applications. Zero and span adjustments are accessible from the outside of transmitters.



### \*SPECIFICATIONS

ACCURACY:	ACCURACY %FS			OPTIONAL ENHANCED ACCURACY %FS		
	<b>MODEL:</b>	GC1, 3, 4	GC5, 6, 7		<b>MODEL:</b>	GC5, 6, 7
<b>FLOW RANGE:</b>	0-100%	20-100%	0-20%	<b>FLOW RANGE:</b>	20-100%	0-20%
<b>ACCURACY:</b>	±1.0%	±1.5%	±3%	<b>ACCURACY:</b>	±1%	±1.0% REF DATA with ±1%

**CALIBRATIONS:** Performed at standard conditions [14.7 psia (101.4 kPa) and 70 °F (21.1°C)] unless otherwise requested.

**REPEATABILITY:** ±0.25% of full scale.

**RESPONSE TIME:** Generally 2 seconds to within ±2% of actual flow rate over 25 to 100% of full scale.

**TEMPERATURE COEFFICIENT:** 0.15% of full scale / °C.

**PRESSURE COEFFICIENT:** 0.01% of full scale / psi (0.07 bar).

**PRESSURE DROP:** See Table above.

**OPTIMUM GAS PRESSURE:** 25 psig (1.73 bars).

**MAX. GAS PRESSURE:** 1000 psig (70 bars) maximum GC1, 3, 4. 500 psig (34.5 bars) GC5, 6, 7.

**TURN DOWN RATIO:** 40:1.

**MAX. DIFF. PRESSURE:** 50 psi for GC1/3/5/6 and 7 (3.4 bars), 40 psi for 47 (2.7 bars).

**GAS and AMBIENT TEMP:** 32 °F to 122 °F (0 °C to 50 °C). 14 °F to 122 °F (-10 °C to 50 °C) - Dry gases only.

**\*\*MATERIALS FLUID CONTACT:**

- Aluminum models GC Series: anodized aluminum, 316 stainless steel, brass and FKM O-rings.
- Stainless steel models GC1S, 3S, 4S, 5S, 6S and 7S: 316 stainless steel and FKM O-rings.  
Optional O-rings: Buna®, EPR and Kalrez®.

**ATTITUDE SENSITIVITY:** No greater than ±15 degree rotation from horizontal to vertical; standard calibration is in horizontal position.

**OUTPUT SIGNALS:** Linear 0-5 Vdc. (1000 ohms min. load impedance); 4-20 mA (0-500 ohms loop resistance) Max noise ±20mV.

**COMMAND SIGNALS:** Analog 0-5 Vdc or 4-20 mA for remote set point mode; NPN compatible purge /valve off.

**CONNECTIONS:**

- GC1:** 1/4" compression fittings. *Optional:* 6mm, 3/8" and 1/8" compression fittings or 1/4" VCR®.
- GC3:** 1/4" compression fittings. *Optional:* 6mm and 3/8" compression fittings or 1/4" VCR®.
- GC4:** 3/8" compression fittings.
- GC5:** 3/8" compression fittings.
- GC6:** 1/2" compression fittings.
- GC7:** 3/4" FNPT fittings. *Optional:* 3/4" compression fittings.

**LEAK INTEGRITY:** 1 x 10<sup>-9</sup> sml/sec of helium maximum to the outside environment.

**TRANSDUCER INPUT POWER:**  
GC1, 3 and 4: Universal +12 Vdc to 26 Vdc, 650 mA maximum.  
GC5, 6 and 7: +12 Vdc, 800 mA; +24 Vdc, 650 mA optional.

**CIRCUIT PROTECTION:** Circuit boards have built-in polarity reversal protection. Resettable fuses provide power input protection.

**DISPLAY:** 3-1/2 digit LCD, 0.5" high characters.

**CE COMPLIANT:** EN 55011 class 1, class B; EN50082-1.

\* The selection of materials of construction, is the responsibility of the customer. The company accepts no liability.

## Aluminum and Stainless Mass Flow Controllers



### DESIGN FEATURES

- ✓ Rigid metallic construction.
- ✓ Maximum pressure of 1000 psig (70 bars) for GC1, GC3, GC4. 500 psig (34.5 bars) for GC5, GC6 and GC7.
- ✓ Leak integrity  $1 \times 10^{-9}$  smL/sec of helium.
- ✓ NIST traceable certification.
- ✓ Built-in tiltable LCD readout.
- ✓ Local or remote setpoint control.
- ✓ 0-5 Vdc and 4-20 mA signals.
- ✓ Circuit protection.
- ✓ Totalizer option.

MODEL	CONNECTION Compression Fitting (except model GC7)	DIMENSION (INCH)									
		LCD VERSION									NO LCD
		A	B	C/*C	D/*D	E/*E	F	G	H	I	
GC1	1/4" Tube O Diameter	5.60	1.00	1.00	4.27	6.29	0.69	2.68	3.56	4.50	
GC3	1/4" Tube O Diameter	5.98	1.37	1.25	5.19	7.21	0.69	2.68	3.94	4.88	
GC4	3/8" Tube O Diameter	5.98	1.37	1.25	5.19	7.33	0.69	2.68	3.94	4.88	
GC5	3/8" Tube O Diameter	6.60	2.00	1.75	10.2	12.3	0.99	4.68	6.88	5.50	
GC6	1/2" Tube O Diameter	7.56	3.00	3.00	10.0	12.4	-	-	7.55	6.46	
GC7	3/4" NPT Female	8.56	4.00	4.00	10.5	-	-	-	8.05	7.46	

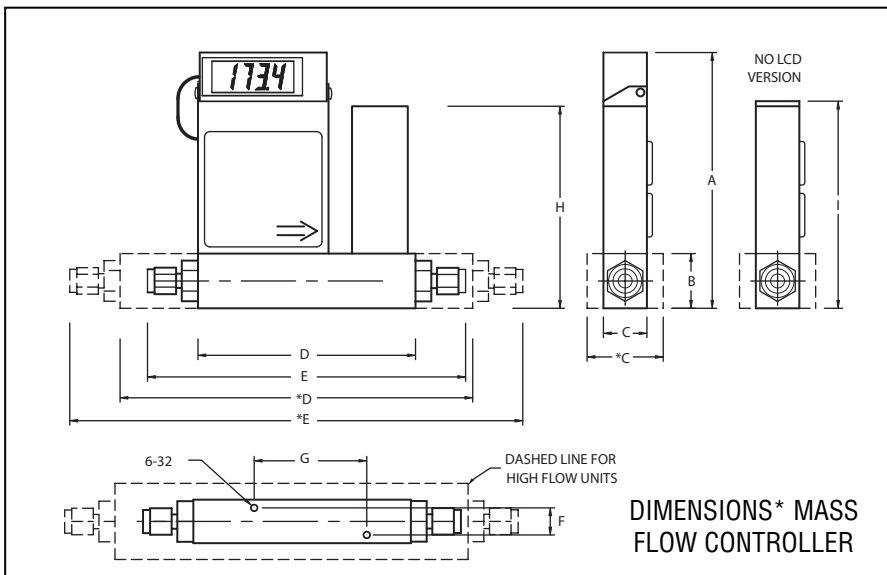

### GENERAL DESCRIPTION

Compact, self contained mass flow controllers are designed to indicate and control flow rates of gases. The rugged design coupled with instrumentation grade accuracy provides versatile and economical means of flow control. Aluminum or stainless steel models with readout options of either engineering units (standard) or 0 to 100 percent displays are available.

The built-in electromagnetic valve allows the flow to be set to any desired flow rate within the range of the particular model. The valve is normally closed as a safety feature to ensure that gas flow is shut off in case of a power outage. Setpoints are controlled either locally or remotely.

The LCD readout built into the top of the transducer is tiltable over 90 degrees to provide optimal reading comfort. It is connected to the transducer by a standard modular plug, and is readily removable for remote reading installations. Transducers without LCD readout are offered for OEM applications.

The combined gas streams flow through a proportionating electromagnetic valve with an appropriately selected orifice. The closed loop control circuit continuously monitors the mass flow output and maintains it at the set flow rate.

Flow rates are unaffected by temperature and pressure variations within stated limitations.

Mass flow controllers are available with flow ranges from 10 sccm to 1000 sL/min N<sub>2</sub>. Gases are connected by means of 1/4", 3/8", or optional 1/8" compression fittings and 3/4" FNPT fittings. Optional fittings are available. These controllers may be used as bench top units or mounted by means of screws in the base. Transducer power supply ports are fuse and polarity protected.

MODEL	FLOW RATE [std liters/min]	MAXIMUM PRESSURE DROP	
		[psid]	[mbar]
GC1	up to 10	1.06	0.075
GC3	20	2.00	0.138
	30	3.5	0.241
	40	5.5	.379
GC4	50	8	.551
	100	18.9	1.302
GC5	200	10	690
GC6	500	12	827
GC7	1000	15	1034