

# INDUSTRIAL STAINLESS STEEL METERS

## FEATURES

- ✓ Heavy duty stainless steel.
- ✓ Thick polycarbonate safety shields.
- ✓ Fluted or plain tapered tubes.
- ✓ Direct reading metric and English system scales.
- ✓ Unique design facilitates ease of maintenance cleaning processes.

Heavy-duty flow meters are fully enclosed in a brushed stainless steel case. Ideal for industrial applications with flow rates of up to 116 GPM / 440 L/min and 250 SCFM / 7080 L/min. Used for flow measurements of liquids (water) and gases (air). Meters are graduated for direct reading of water and air.

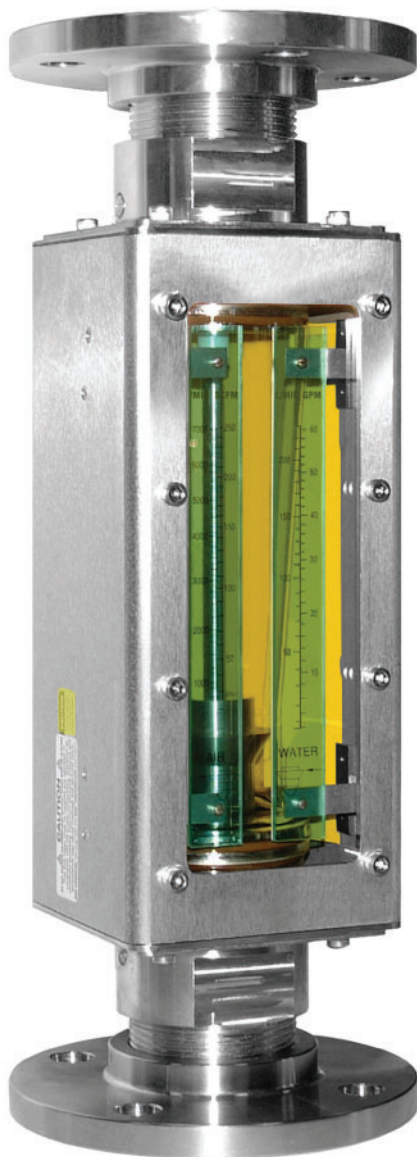

Flow meters come with FNPT or flanged end fittings for easy in-line installation. Wetted parts include borosilicate glass flow tubes, Fkm O-rings, and 316 Stainless steel fittings, guide rods, floats and float stops.

### Flanged Style Meter



Industrial Stainless Steel In-Line Flow Meters

## SPECIFICATIONS

<b>ACCURACY:</b>	±3% of full scale.
<b>MINIMUM FLOW RATE:</b>	Approximately 10% of maximum flow rate.
<b>REPEATABILITY:</b>	±0.5% of full scale.
<b>MAXIMUM PRESSURE AT 200 °F (93 °C):</b>	200 psig / 9.6 bars (tube sizes 3, 4, 5 and 6). 125 psig / 14.8 bars (tube sizes 8 and 9).
<b>MAXIMUM OPERATING TEMPERATURE:</b>	200 °F (93 °C).
<b>FLOW TUBES:</b>	Heavy walled borosilicate glass.
<b>FITTINGS IN CONTACT WITH FLUIDS:</b>	316 Stainless Steel.
<b>FRONT SHIELD:</b>	Thick clear polycarbonate and white acrylics.
<b>O-RINGS:</b>	FKM .
<b>OPTIONAL:</b>	PTFE/ Kalrez®, EPR.
<b>CONNECTIONS:</b>	<b>IN-LINE:</b> 1/2", 1", 2", NPT. <b>150 ANSI FLANGED:</b> 3/4", 1-1/2", 2-1/2".



*The selection of materials of construction, is the is the responsibility of the customer. The company accepts no liability.*

# INDUSTRIAL STAINLESS STEEL METERS

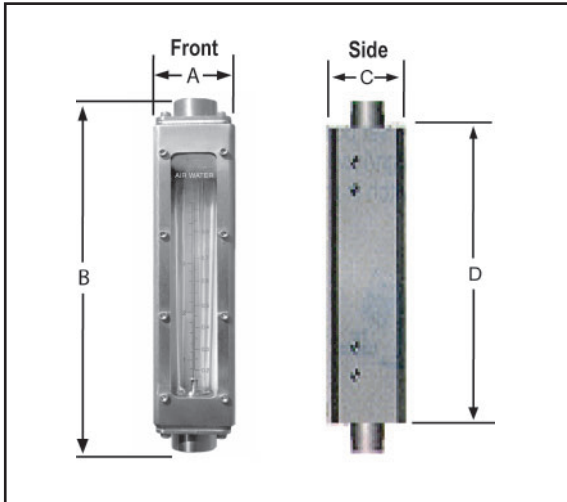

**DIMENSIONS FOR IN-LINE INDUSTRIAL STAINLESS STEEL METERS**

NPT (F)	A	B	C	D
1/2"	2	9.54	2.25	8.04
1"	3.5	13.69	3.75	10.50
2"	5	15.59	5.25	11.55

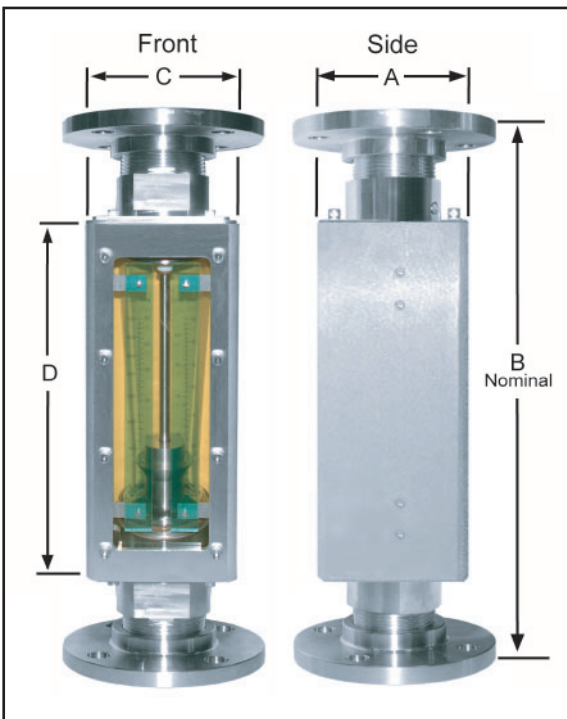

**DIMENSIONS FOR FLANGED INDUSTRIAL STAINLESS STEEL METERS**

NPT (F)	A	B (Nominal)	C	D
3/4"	2	9.58	2.25	8.04
1 1/2"	3.5	14.15	3.75	10.50
2 1/2"	5	17.98	5.25	11.55

**TABLE 32, IN-LINE METERS**

CATALOG NUMBER	MAX FLOW RATE				PRESSURE DROP ("OF H <sub>2</sub> O)	TUBE SIZE	NPT CONNECTION
	WATER (GPM)	AIR (SCFM)	WATER (L/min)	AIR (L/min)			
6AM6101MJ	0.25	1.2	.95	35	3	3	1/2"
6AM6102MJ	0.36	1.9	1.3	54	3	3	
6AM6103MJ	0.76	3.3	3.0	90	7	3	
6AM6104MJ	1.0	4.2	3.8	120	8	4	
6AM6105MJ	1.5	6.5	5.6	180	11	4	
6AM6106MJ	2.2	8.5	8.2	250	14	4	
6AM6107MK	3.8	16	14	480	14	5	1"
6AM6108MK	5.0	22	18	650	20	5	
6AM6109MK	6.0	25	22	725	7	6	
6AM6110MK	7.4	34	27.5	950	8	6	
6AM6111MK	9.6	40	36	1200	14	6	
6AM6112MK	11	47.5	42	1400	18	6	
6AM6113MK	15	62.5	52.5	1800	34	6	2"
6AM6114MK	20	90	80	2600	55	6	
6AM6115MK	22	90	85	2550	23	8	
6AM6116MK	25	-	95	-	99	6	
6AM6117MK	41	170	155	4600	7	9	
6AM6118MK	44	180	165	5000	42	8	
6AM6119MK	60	250	230	7000	23	9	2"
6AM6120MK	62	250	230	7000	70	8	
6AM6121MK	86	-	320	-	35	9	
6AM6122MK	116	-	440	-	56	9	

**TABLE 32-1, FLANGED METERS**

CATALOG NUMBER	MAX FLOW RATE				PRESSURE DROP ("OF H <sub>2</sub> O)	TUBE SIZE	FLANGE CONNECTION
	WATER (GPM)	AIR (SCFM)	WATER (L/min)	AIR (L/min)			
6AM8101MJ	0.25	1.2	.95	35	3	3	3/4"
6AM8102MJ	0.36	1.9	1.3	54	3	3	
6AM8103MJ	0.76	3.3	3.0	90	7	3	
6AM8104MJ	1.0	4.2	3.8	120	8	4	
6AM8105MJ	1.5	6.5	5.6	180	11	4	
6AM8106MJ	2.2	8.5	8.2	250	14	4	
6AM8107MK	3.8	16	14	480	14	5	1 1/2"
6AM8108MK	5.0	22	18	650	20	5	
6AM8109MK	6.0	25	22	725	7	6	
6AM8110MK	7.4	34	27.5	950	8	6	
6AM8111MK	9.6	40	36	1200	14	6	
6AM8112MK	11	47.5	42	1400	18	6	
6AM8113MK	15	62.5	52.5	1800	34	6	2 1/2"
6AM8114MK	20	90	80	2600	55	6	
6AM8115MK	22	90	85	2550	23	8	
6AM8116MK	25	-	95	-	99	6	
6AM8117MK	41	170	155	4600	7	9	
6AM8118MK	44	180	165	5000	42	8	
6AM8119MK	60	250	230	7000	23	9	2 1/2"
6AM8120MK	62	250	230	7000	70	8	
6AM8121MK	86	-	320	-	35	9	
6AM8122MK	116	-	440	-	56	9	